





Smalterie Metallurgiche Emiliane Guastalla

Distinctive domestic appliances developed in collaboration with leading architects of the world.

Products that express "Made in Italy" by perfectly combining design, performance, and attention to detail.

Smeg. Technology with style.

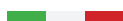

Premium quality and Design

Index

22

DOLCE STIL NOVO



43

LINEA



76

HOODS

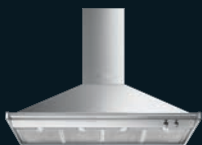

98

BUILT-IN COOLING



103

DISHWASHERS

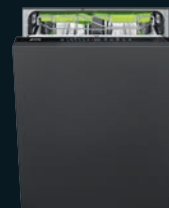

55

CORTINA



94

CLASSICA



105

TAPS



111

COOKERS



123

REFRIGERATORS



158

SMALL DOMESTIC
APPLIANCES



- 1948** Vittorio Bertazzoni Sr founds Smeg (Smalterie Metallurgiche Emiliane Guastalla) in Guastalla, near Reggio Emilia in Italy.
- 1955** Production of cookers begins, reaching its peak with the presentation of the first Smeg brand cooker, Elisabeth, in 1956.
- 1963** The company presents Leda, the first Smeg branded washing machine, thanks to an increase in production capacity to include laundry appliances.
- 1970** Niagara is released, the world's first 14-place setting dishwasher, meeting modern requirements for large wash capacities.
- 1971** Production of built-in appliances such as ovens and hobs begins; these products will become part of the defining elements of Smeg's success.
- 1977** 1977 Franco Maria Ricci, one of Italy's most illustrious publishers and graphic designers, creates the Smeg logo which incorporates references to the burners of a gas hob and the round knobs of an oven. Smeg also begins its sponsorship of legendary Ferrari driver Gilles Villeneuve.
- 1985** Instinctively and incisively understanding new consumer requirements for more elegant products, the company begins working with architect Guido Canali to create ovens and hobs.
- 1991** Smeg's collaboration with important designers continues, with the company offering ovens and hobs designed by architect Mario Bellini.
- 1995** The company begins working with architect Renzo Piano, a collaboration which will lead to the production of hobs, ovens, fridges and the Smeg home garden.
- 1997** 1997 The FAB range of fridges is created, a product line destined to become an international style icon and status symbol.
- 2002** Guido Canali designs the Smeg Headquarters, for which he receives an honourable mention at the Milan Triennale's "medaglia d'Oro all'Architettura Italiana" architectural awards in 2006.
- 2008** Smeg celebrates its 60th anniversary and presents products designed alongside Marc Newson, which leads to winning the Wallpaper Design Award the following year.
- 2010** Smeg receives the Good Design Award for an oven and hob from the Linea aesthetics. The same prestigious recognition will also be assigned in 2012 and 2013 for other products in the range.
- 2012** The first denim-covered fridge, created in collaboration with Italia Independent, is released, followed the next year by the Smeg500, a fridge which looks like a Fiat 500 car.
- 2014** The 50s Style small appliances line, created together with the deepdesign© studio, makes its début and immediately wins over both customers and critics. Smeg wins the Good Design award once again, as well as the iF Design Award and Red Dot Design Award.
- 2017** Professional style Portofino cookers with triple-fan cavities are added to the range. A concession in world famous luxury department store, Harrods, and a flagship Smeg store open in the heart of London.
- 2019** The Vitality System, Smeg Connect, Portofino Multicavity and a Disney Mickey Mouse special edition FAB are all introduced to the range. A new collaboration with D&G produces the "Divina Cucina" collection, and Smeg announces the acquisition of La Pavoni coffee machines.
- 2022** Smeg presents Galileo, the new generation of ovens with Multicooking technology. They combine traditional cooking, steam and microwaves to enhance performance for professional quality results every time.

HISTORY

Smeg has been producing domestic appliances with the finest Italian design for more than 70 years, with a particular focus on aesthetics, ergonomics and functionality.

Today Smeg, originally an acronym for **Smalterie Metallurgiche Emiliane Guastalla** indicating its initial activities in enamel work and metallurgy, has reached its third generation of entrepreneurs and represents an international group with direct subsidiaries and distributors in all five continents.

Smeg believes that objects of daily use should not only fill an environment; they should create an atmosphere. This sensitivity, which has inspired the collaboration with great architects and designers of our time, is the perfect expression of Made in Italy which combines art and industrial expertise in everyday objects.





COORDINATING COLLECTION

Style, for Smeg, is a distinct concept: the way a product communicates with its surroundings and enables users to interact with it. Every aesthetic design family offers a choice of different coordinating products. Aesthetic lines are presented in a wide range of appliances and can be coordinated throughout the kitchen to create a powerful style statement.





DOLCE STIL NOVO

Dolce Stil Novo presents the ultimate style and embodies all the latest innovations, making these appliances leaders in their segment. The play of light and shadow and the technical excellence of the products in its aesthetics are the distinctive features of this range.





LINEA

Distinctive products that incorporate modern minimalist design trends, the Linea aesthetics is characterised by symmetrical lines, balance and light. A series of ovens, coffee machines, hobs, hoods, fires and accessories are all extremely ergonomic and designed to maximise the available space, making a real style statement in the kitchen.





CLASSICA

Strict forms, simple and essential design for a timeless style, yet with a contemporary feel. Smeg Classica is made of a series of iconic and elegant domestic appliances that are finished in smart stainless steel. Ovens, coffee machines, hobs, hoods, fridges, dishwashers and more make a real impact with their smooth and sleek design lines.





50'S RETRO STYLE

Colour and retro lines for style icons: Smeg 50's Retro Style refrigerators embody the glamour and rounded forms of the 1950's and become real cult objects. Rounded shapes, chrome details and bright colours make any space hum with style and character.





CORTINA

The inspiration for the Cortina design came from master artisan wrought iron work traditionally produced in the Italian mountains. This style embodies the unique lines of alpine chalet architecture and ancient Italian estates. The combination of forged iron and refined forms adds an unrepeatable charm and fascination to these appliances.

SMEG PRODUCTS

Smeg products, the perfect combination of refined aesthetics and technological reliability, have transformed simple kitchen appliances into designer furnishings, undisputed examples of the finest Italian design. A range of fully coordinated domestic appliances with unmistakably refined aesthetics and a well-defined identity of its own.



PV695LCNR

PVL6106CN

GAS, HOB, DOLCE STIL NOVO, 100 CM, BLACK

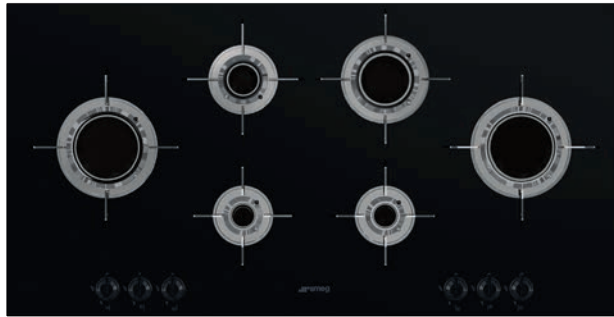

PLUS:



Built-in type: Ultra-low profile or Fully Flushed

Centre-left: 3.50 kW

Rear-left: 1.60 kW

Front-left: 1.00 kW

Rear-right: 2.50 kW

Front-right: 1.00 kW

Centre-right: 3.50 kW

Stainless steel

Gas safety valves

Ceramic glass

Straight edge

Control knob position: Front

Laminate

Burners Material: Brass

Burner Coating: Nichelato

Controls colour: Black

Voltage (V): 220-240 V

Frequency (Hz): 50/60 Hz

Electrical connection rating (W): 1 W

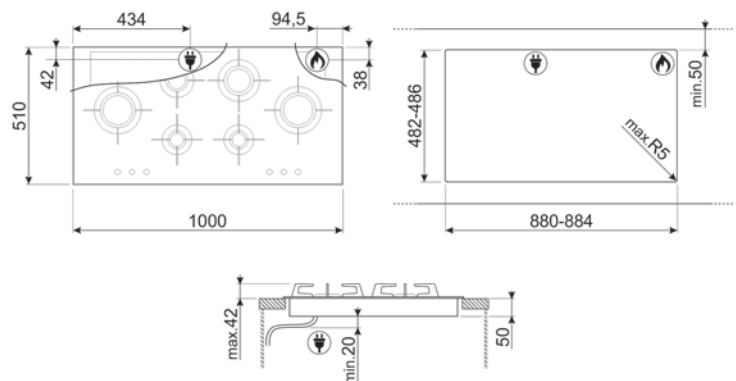

PV664LCNR

GAS, HOB, DOLCE STIL NOVO, 65 CM,
BLACK, COPPER



PLUS:



Built-in type: Traditional
 Left: 3.10 kW
 Rear-centre: 1.70 kW
 Front-centre: 1.10 kW
 Right: 2.60 kW
 Cast iron
 Gas safety valves
 Ceramic glass
 Straight edge
 Control knob position: Front
 Smeg Contemporary
 Burners Material: Alluminium
 Burner Coating: Black Ceram
 Controls colour: Black

Voltage (V): 220-240 V
 Frequency (Hz): 50/60 Hz
 Electrical connection rating (W): 1 W

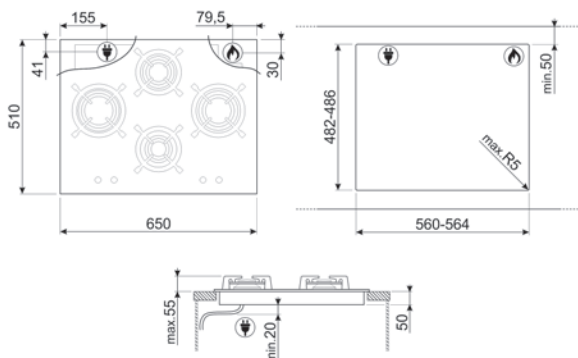

PV695LCNR

GAS, HOB, DOLCE STIL NOVO, 90 CM, BLACK, COPPER



PLUS:



Built-in type: Traditional
 Left: 6.00 kW
 Rear-centre: 1.70 kW
 Front-centre: 1.70 kW
 Rear-right: 2.60 kW
 Front-right: 1.10 kW
 Cast iron
 Gas safety valves
 Ceramic glass
 Straight edge
 Control knob position: Front
 Smeg Contemporary
 Burners Material: Alluminium
 Burner Coating: Black Ceram
 Controls colour: Black

Voltage (V): 220-240 V
 Frequency (Hz): 50/60 Hz
 Electrical connection rating (W): 1 W

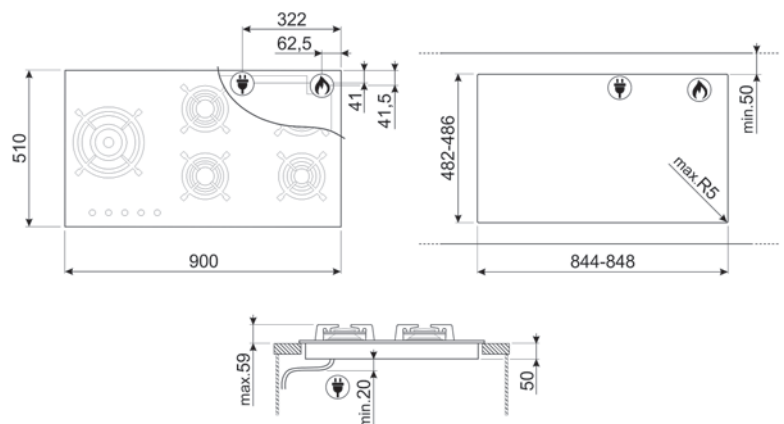



PM6643R

MIXED, HOB, DOLCE STIL NOVO, 65 CM, BLACK, MULTIZONE OPTION



PLUS:

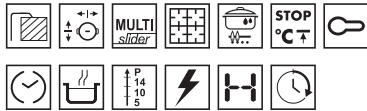

MultiZone

Built-in type: Ultra-low profile

No. of induction cook zones: 2

Front-left: 1.10 kW

Rear-left: 3.10 kW

Rear-right: 18.0x23.0 cm, 2.10 kW - 3.60 kW

3rd zone booster power: 3.60 kW

Front-right: 18.0x23.0 cm, 2.10 kW - 3.60 kW

4th zone booster power: 3.60 kW

Power levels: 9

Right Multizone dimension: 38.5x23.0 cm

Bridge option: Yes

Cast iron

Rapid level selection

Automatic setting according to pan dimension

pan detection: Yes

Automatic switch off when overheat

Automatic switch off when overflow

Protection against accidental start up

Gas safety valves

Straight edge

Control knob position: Front

Smeg Contemporary

Burners Material: Brass

Controls colour: Steel effect

Control Lock / Child Safety

Voltage (V): 220-240 V

Frequency (Hz): 50/60 Hz

Current: 16 A

Electrical connection rating (W): 3700 W

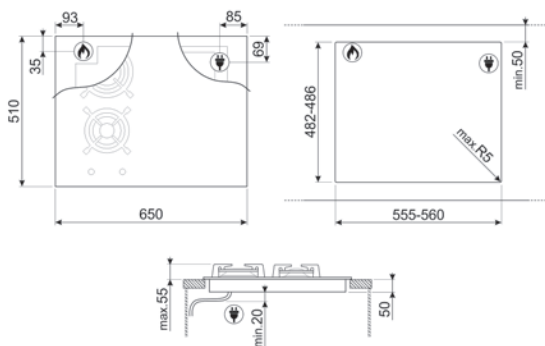

PM6954R

MIXED, HOB, DOLCE STIL NOVO, 90 CM, BLACK, MULTIZONE OPTION



PLUS:

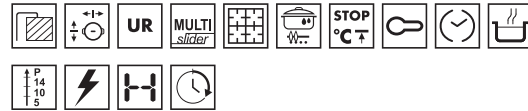

MultiZone

Built-in type: Traditional

No. of induction cook zones: 4

Centre-left: 6.00 kW - 2.5 kW

1st zone booster power: 2.5 kW

Rear-centre: 24.0x18.0 cm, 2.10 kW - 2.50 kW

2nd zone booster power: 2.50 kW

Front-centre: 24.0x18.0 cm, 2.10 kW - 2.50 kW

3rd zone booster power: 2.50 kW

Rear-right: 24.0x18.0 cm, 2.10 kW - 2.50 kW

4th zone booster power: 2.50 kW

Front-right: 24.0x18.0 cm, 2.10 kW - 2.50 kW

5th zone booster power: 2.50 kW

Power levels: 9

Central Multizone dimension: 38.5x23.0 cm

Right Multizone dimension: 38.5x23.0 cm

Bridge option: Yes

Cast iron

Rapid level selection

Automatic setting according to pan dimension

pan detection: Yes

Automatic switch off when overheat

Automatic switch off when overflow

Protection against accidental start up

Gas safety valves

Straight edge

Control knob position: Front

Smeg Contemporary

Burners Material: Brass

Controls colour: Steel effect

Control Lock / Child Safety

Voltage (V): 220-240 V

Voltage 2 (V): 380-415 V

Frequency (Hz): 50/60 Hz

Current: 33 A

Electrical connection rating (W): 7400 W

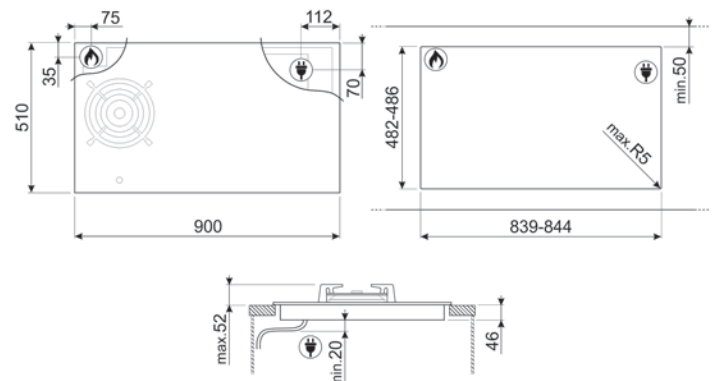

HOBD682R1

INDUCTION WITH INTEGRATED HOOD, HOB, DOLCE STIL NOVO, 80 CM, COPPER, BLACK, MULTIZONE OPTION



PLUS:



MultiZone

Built-in type: Traditional

No. of induction cook zones: 4

Left: 23.0x21.0 cm, 2.10 kW - 3.70 kW

1st zone booster power: 3.70 kW

Right: 23.0x21.0 cm, 2.10 kW - 3.70 kW

2nd zone booster power: 3.70 kW

3rd zone booster power: 3.70 kW

4th zone booster power: 3.70 kW

Power levels: 9

Left Multizone dimension: 46.0x21.0 cm

Right Multizone dimension: 46.0x21.0 cm

Cast iron

Simmering Function

Melting/Low temperature cooking function

Rapid level selection

Automatic setting according to pan dimension

pan detection: Yes

Automatic switch off when overflow

Protection against accidental start up

Ceramic glass

Straight edge

Control knob position: Front

Control Lock / Child Safety

Voltage (V): 220-240 V

Voltage 2 (V): 380-415 V

Frequency (Hz): 50/60 Hz

Current: 33 A

Electrical connection rating (W): 7545 W

HOOD

Free outlet maximum capacity: 750 m³/h

Motor power: 220 W

No. of filters: 1

Anti-grease filters: Alluminio

Filter replacement indicator

HOOD CONTROLS

Touch Capacitive

Display

Led color: Bianco

HOOD FUNCTIONS

No. of speeds: 8

Intensive speed: 2

Other functions: AUTOVENT

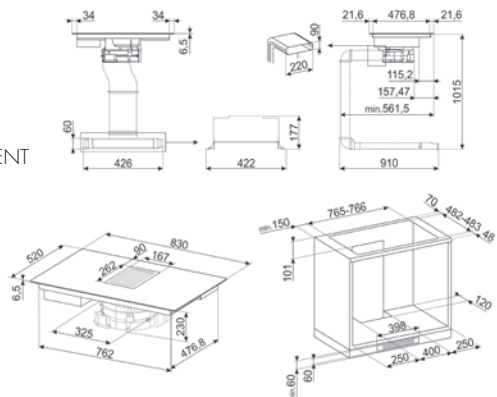

SIM6964R

INDUCTION, HOB, DOLCE STIL NOVO, 90 CM, BLACK, MULTIZONE OPTION



PLUS:



MultiZone

Built-in type: Traditional

No. of induction cook zones: 6

Front-left: 24.0x18.0 cm, 2.10 kW - 2.50 kW

1st zone booster power: 2.50 kW

Rear-left: 24.0x18.0 cm, 2.10 kW - 2.50 kW

2nd zone booster power: 2.50 kW

Front-centre: 24.0x18.0 cm, 2.10 kW - 2.50 kW

3rd zone booster power: 2.50 kW

Rear-centre: 24.0x18.0 cm, 2.10 kW - 2.50 kW

4th zone booster power: 2.50 kW

Front-right: 24.0x18.0 cm, 2.10 kW - 2.50 kW

5th zone booster power: 2.50 kW

Rear-right: 24.0x18.0 cm, 2.10 kW - 2.50 kW

6th zone booster power: 2.50 kW

Power levels: 9

Central Multizone dimension: 38.5x23.0 cm

Left Multizone dimension: 38.5x23.0 cm

Right Multizone dimension: 38.5x23.0 cm

Bridge option: si-AUTO

Rapid level selection

Automatic setting according to pan dimension

pan detection: Yes, min 9 cm

Automatic switch off when overflow

Automatic switch off when overheating

Protection against accidental start up

Straight edge

Control knob position: Front

Control Lock / Child Safety

Voltage (V): 220-240 V

Voltage 2 (V): 380-415 V

Frequency (Hz): 50/60 Hz

Current: 49 A

Electrical connection rating (W): 11100 W

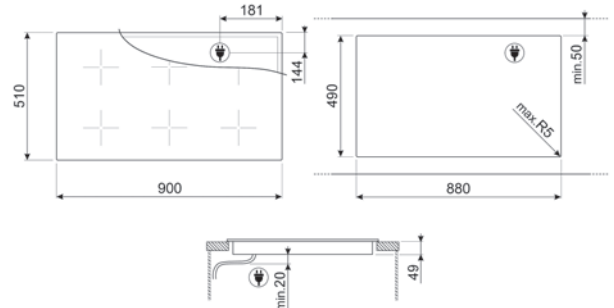

PV631CNR

GAS, HOB, DOLCE STIL NOVO,
38 CM, BLACK, COPPER



PLUS:



Built-in type: Traditional
Central: 6.00 kW
Cast iron
Gas safety valves
Ceramic glass
Straight edge
Control knob position: Front
Smeg Contemporary
Burners Material: Alluminium
Burner Coating: Black Ceram
Controls colour: Black

Voltage (V): 220-240 V
Frequency (Hz): 50/60 Hz
Electrical connection rating (W):
1 W

PV632CNR

GAS, HOB, DOLCE STIL NOVO,
38 CM, BLACK, COPPER



PLUS:



Built-in type: Traditional
Front-centre: 1.10 kW
Rear-centre: 3.10 kW
Cast iron
Gas safety valves
Ceramic glass
Straight edge
Control knob position: Front
Smeg Contemporary
Burners Material: Alluminium
Burner Coating: Black Ceram
Controls colour: Black

Voltage (V): 220-240 V
Frequency (Hz): 50/60 Hz
Electrical connection rating (W):
1 W

SIM6323R

HOB, DOLCE STIL NOVO,
38 CM, BLACK, COPPER



PLUS:

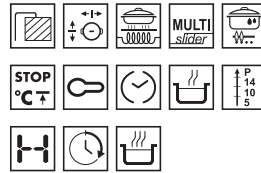

MultiZone
Built-in type: Traditional
No. of induction cook zones: 2
Front-centre: 18.0x23.0 cm,
2.10 kW - 3.60 kW
1st zone booster power:
3.60 kW
Rear-centre: 18.0x23.0 cm,
2.10 kW - 3.60 kW
2nd zone booster power:
3.60 kW
Power levels: 9
Central Multizone dimension:
38.5x23.0 cm
Simmering Function
Melting/Low temperature
cooking function
Rapid level selection
Automatic setting according to
pan dimension
pan detection: Yes, min 9 cm
Automatic switch off when
overheat
Automatic switch off when
overflow
Protection against accidental
start up
Straight edge
Control knob position: Front
Control Lock / Child Safety

Voltage (V): 220-240 V
Frequency (Hz): 50/60 Hz
Current: 16 A
Electrical connection rating (W):
3700 W

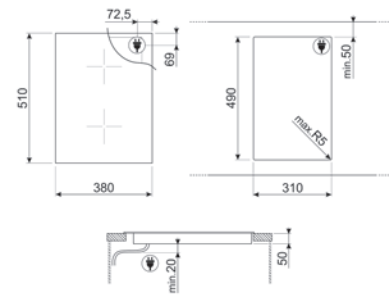
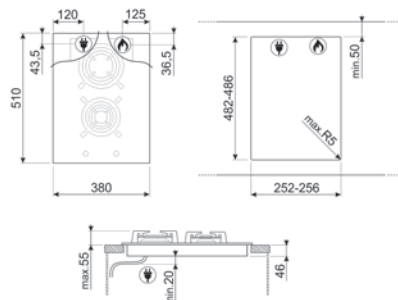
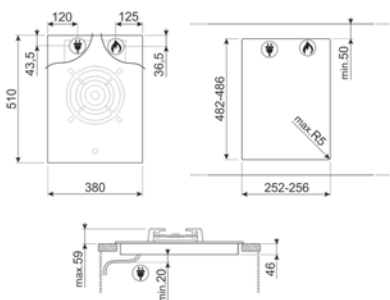



KV694R

DECORATIVE WALL HOOD, DOLCE STIL NOVO, 90 CM, BLACK



PLUS:



No. of speeds	I	II	III	INT
Extraction rate IEC 61591 m ³ /h	265	391	621	777
Noise level IEC 60704-2- 13 dB(A)	47	55	66	70

Motor power: 275 W
 Free outlet maximum capacity: 820 m³/h
 Black
 Electronic control
 Touch control back-lighted White
 No. of speeds: 3
 Intensive speed
 Time-setting options
 2 st/steel grease filters
 Vent outlet: 150 mm
 Non return valve
 Fluid Dynamic Efficiency class (FDEC): A
 Lighting Efficiency Class (LEC): A
 Grease Filtering Efficiency Class (GFEC): E
 Sound power level at highest setting (Lwa): 67 dB(A)

Frequency (Hz): 50-60 Hz
 Voltage: 220-240 V

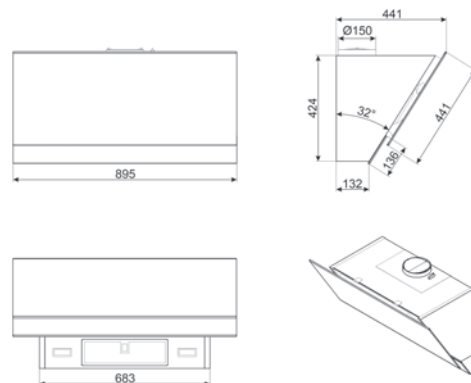



SO6606WS4PNR

SO6606WS4PNR

COMBINATION STEAM OVEN, VAPOR CLEAN, DOLCE STIL NOVO, 60CM, BLACK



PLUS:

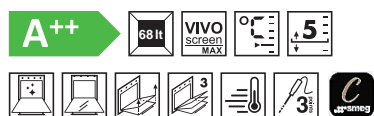

FUNCTIONS:



Gross volume: 79 l
 Net volume of the cavity: 68 l
 Automatic programmes: 150
 Customisable recipes: 10
 Display: 06 - 05
 Display technology: TFT
 Delay start and automatic end cooking
 Door opening type: Standard opening
 Minute minder: Yes
 Timer: Electronic
 End of cooking acoustic alarm
 Temperature control: Electronic
 Heating suspended when door is opened
 Temperatures: from 30°C to 250°C
 Soft Close hinges
 Eclipse
 Light when door is opened

Nominal power: 3000 W
 Energy consumption per cycle in conventional mode: 1.09 kWh
 Energy consumption in conventional mode: 3.92 MJ
 Energy consumption per cycle in fan-forced convection: 0.51 kWh
 Energy consumption in forced air convection: 1.84 MJ

Frequency (Hz): 50/60 Hz
 Current: 13 A
 Voltage: 220-240 V

ACCESSORIES INCLUDED:

Insert grid: 1
 Temperature probe
 St/steel perforated deep tray (40mm): 1
 St/steel tray (20mm): 1

SO6606WAPNR

COMBINATION MULTITECH OVEN, VAPOR CLEAN, DOLCE STIL NOVO, 60CM, BLACK, COPPER



PLUS:



FUNCTIONS:



Copper
 Gross volume: 79 l
 Net volume of the cavity: 68 l
 Automatic programmes: 150
 Customisable recipes: 10
 Display: 06 - 05
 Display technology: TFT
 Delay start and automatic end cooking
 Door opening type: Standard opening
 Minute minder: Yes
 Timer: Electronic
 End of cooking acoustic alarm
 Temperature control: Electronic
 Heating suspended when door is opened
 Temperatures: from 30°C to 250°C
 Soft Close hinges
 Eclipse
 Light when door is opened

Nominal power: 3000 W
 Microwave effective power: 900 W

Frequency (Hz): 50/60 Hz
 Current: 13 A
 Voltage: 220-240 V

ACCESSORIES INCLUDED:

Insert grid: 1
 Temperature probe
 St/steel perforated deep tray (40mm): 1
 St/steel tray (20mm): 1

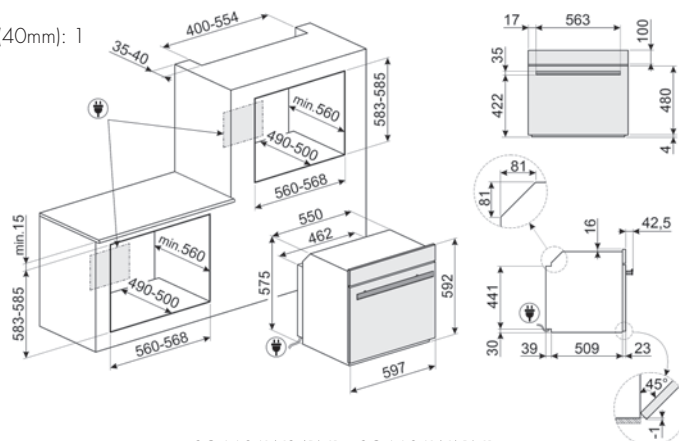

SO6606WS4PNR - SO6606WAPNR

SO6604S4PNR

COMBINATION STEAM OVEN, VAPOR CLEAN, DOLCE STIL NOVO, 60CM, BLACK, COPPER



PLUS:

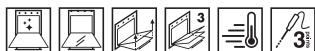

FUNCTIONS:



Copper

Gross volume: 79 l
 Net volume of the cavity: 68 l
 Automatic programmes: 150
 Customisable recipes: 10
 Display: 04 - 03
 Display technology: TFT
 Delay start and automatic end cooking
 Door opening type: Standard opening
 Minute minder: Yes
 Timer: Electronic
 End of cooking acoustic alarm
 Temperature control: Electronic
 Heating suspended when door is opened
 Temperatures: from 30°C to 250°C
 Soft Close hinges
 Eclipse
 Light when door is opened
 2 halogen lamps (40 W)

Nominal power: 3000 W
 Energy consumption per cycle in conventional mode: 1.09 kWh
 Energy consumption in conventional mode: 3.92 MJ
 Energy consumption per cycle in fan-forced convection: 0.51 kWh
 Energy consumption in forced air convection: 1.84 MJ

Frequency (Hz): 50/60 Hz
 Current: 13 A
 Voltage: 220-240 V

ACCESSORIES INCLUDED:

Insert grid: 1
 Temperature probe
 St/steel perforated deep tray (40mm): 1
 St/steel tray (20mm): 1

SOP6604TPNR

THERMO-VENTILATED OVEN, PYROLITIC, DOLCE STIL NOVO, 60CM, BLACK, COPPER



PLUS:



FUNCTIONS:



Copper

Gross volume: 78 l
 Net volume of the cavity: 68 l
 Automatic programmes: 150
 Customisable recipes: 10
 Display: 04 - 03
 Display technology: TFT
 Delay start and automatic end cooking
 Door opening type: Standard opening
 Minute minder: Yes
 Timer: Electronic
 End of cooking acoustic alarm
 Temperature control: Electronic
 Heating suspended when door is opened
 Door Lock During Pyrolysis
 Temperatures: from 30°C to 280°C
 Soft Close hinges
 Eclipse
 Light when door is opened
 2 halogen lamps (40 W)

Nominal power: 3000 W
 Energy consumption per cycle in conventional mode: 1.09 kWh
 Energy consumption in conventional mode: 3.92 MJ
 Energy consumption per cycle in fan-forced convection: 0.68 kWh
 Energy consumption in forced air convection: 2.45 MJ

Frequency (Hz): 50/60 Hz
 Current: 13 A
 Voltage: 220-240 V

ACCESSORIES INCLUDED:

Enamelled tray (20mm): 1
 Insert grid: 1
 Temperature probe
 Telescopic Guide rails, total Extraction: 1

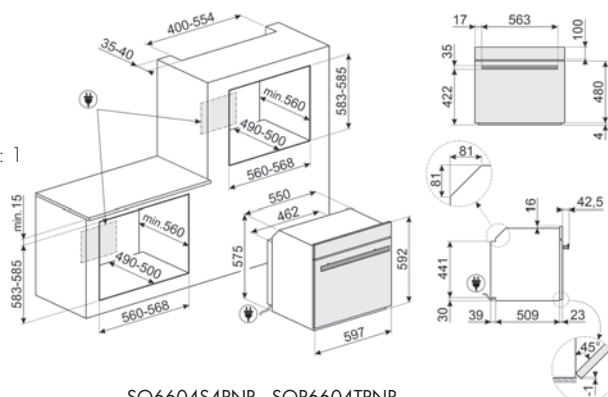

SO6604S4PNR - SOP6604TPNR

SO4604S4PNR

COMBINATION STEAM OVEN, VAPOR CLEAN, DOLCE STIL NOVO, 45 CM, BLACK



PLUS:



FUNCTIONS:



Gross volume: 50 l
 Net volume of the cavity: 41 l
 Automatic programmes: 150
 Customisable recipes: 10
 Display: 04 - 03
 Display technology: TFT
 Delay start and automatic end cooking
 Door opening type: Standard opening
 Minute minder: Yes
 Timer: Electronic
 End of cooking acoustic alarm
 Temperature control: Electronic
 Heating suspended when door is opened
 Temperatures: from 30°C to 250°C
 Soft Close hinges
 Eclipse
 Light when door is opened

Nominal power: 3000 W
 Energy consumption per cycle in conventional mode: 0.80 kWh
 Energy consumption in conventional mode: 2.88 MJ
 Energy consumption per cycle in fan-forced convection: 0.44 kWh
 Energy consumption in forced air convection: 1.58 MJ

Frequency (Hz): 50/60 Hz
 Current: 13 A
 Voltage: 220-240 V

ACCESSORIES INCLUDED:

Insert grid: 1
 Temperature probe
 St/steel perforated deep tray (40mm): 1
 St/steel tray (20mm): 1

SO4604M2PNR

COMBINATION MICROWAVE OVEN, VAPOR CLEAN, DOLCE STIL NOVO, 45 CM, BLACK, COPPER



PLUS:

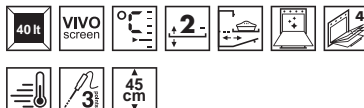

FUNCTIONS:



Copper

Gross volume: 50 l
 Net volume of the cavity: 40 l
 Automatic programmes: 150
 Customisable recipes: 64
 Display: 04 - 03
 Display technology: TFT
 Delay start and automatic end cooking
 Door opening type: Standard opening
 Minute minder: Yes
 Timer: Electronic
 End of cooking acoustic alarm
 Temperature control: Electronic
 Heating suspended when door is opened
 Temperatures: from 30°C to 250°C
 Soft Close hinges
 Eclipse
 Light when door is opened
 Tilting grill

Nominal power: 3000 W
 Microwave screen protection
 Microwave effective power: 900 W

Frequency (Hz): 50/60 Hz
 Current: 13 A
 Voltage: 220-240 V

ACCESSORIES INCLUDED:

Glass tray: 1
 Insert grid: 1
 Temperature probe
 Telescopic Guide rails, total Extraction: 1

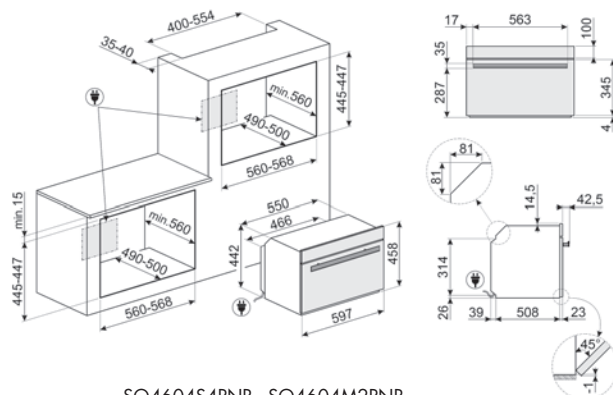

SO4604S4PNR - SO4604M2PNR



FMI625CN

FMI625CN

MICROWAVE, BUILT-IN, DOLCE STIL NOVO,
BLACK



PLUS:



Combi Microwave
Automatic programmes: 10
Other Microwave functions: Multi-session
cooking
Gross volume: 25 l
Net volume: 25 l
Stainless steel
1 a LED
End of cooking acoustic alarm
Eclipse
Door: Full glass
End cooking
Quick start option
Light when door is opened
Turntable dimensions: 31.5 cm
Grid: 1
Shelves type: Rack
Frame
Microwave stops when door is opened
Microwave screen protection
Microwave effective power: 900 W
Circulaire heating element - Power:
2500 W
Safety Thermostat
Touch control

Frequency (Hz): 50 Hz
Current: 11 A
Voltage (V): 230 V

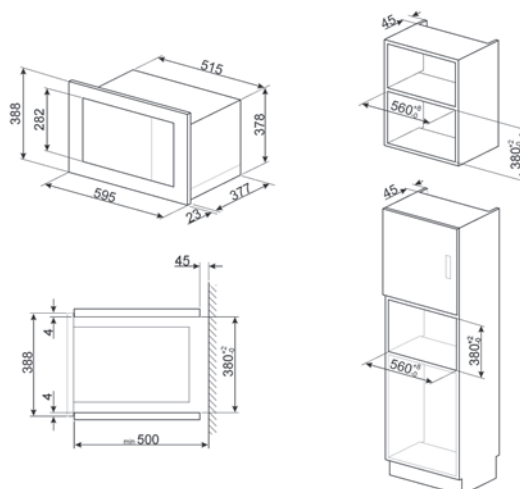



CMS4604NR

CMS4604NR

COFFEE MACHINE, DOLCE STIL NOVO,
45 CM COMPACT, BLACK, COPPER



PLUS:



Copper
Eclipse
Automatic Cappuccino maker with separate tank for milk
Coffee function (double)
Coffee function (single)
Variable coffee temperature: 3 levels
Variable coffee length: 5 levels
Adjustable coffee intensity: 5 levels
Hot water function: for Tea or other drinks
Ground coffee option
Steam dispenser
Thermal carafe: Yes, stainless steel 0,5 L with autoclean system
Cup holder: Yes, warmed
Programmed automatic switch-on
Removable milk jug
Adjustable cappuccino foam
At every switch on/off
Lack of water signal
Coffee granule container capacity: 350 g
Coffee granules compartment
Ground coffee compartment
Removable water container
Used coffee waste container
Drip tray
Automatic descaling
Water container capacity: 2.40 l
Water hardness
Adjustable coffee grinder

Current: 5.6 A
Frequency (Hz): 50-60 Hz
Nominal power: 1350 W
Voltage (V): 220-240 V

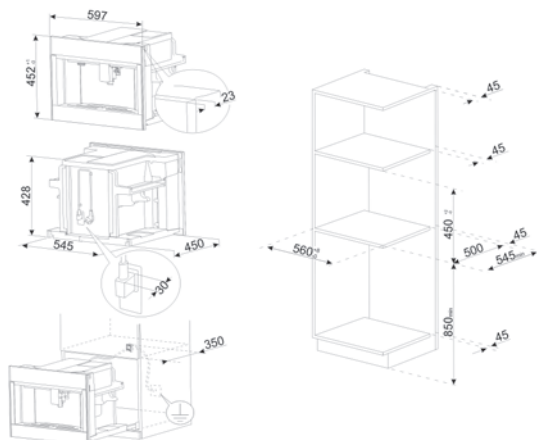

Cprt615NR

DRAWER, REHEAT, DOLCE STIL NOVO,
15 CM, BLACK, COPPER

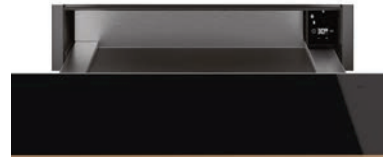

Front panel: With horizontal strip
Eclipse
Copper
Control knobs
Opening mechanism: Push-pull
Capacity: 21 l
Minimum temperature: 30°
Maximum temperature: 80 °C
Reheating
Defrost
Keep warm
Dish warmer
Max weight allowance: 15 kg

15 cm

Current: 2 A
Frequency (Hz): 50-60 Hz
Nominal power: 400 W
Voltage (V): 220-240 V

Accessories included: Silicone antislip mat

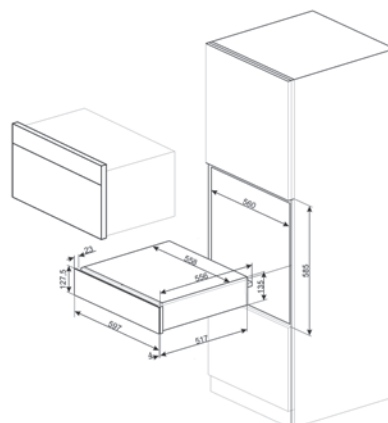



CV1621NR3

CVI621NR3

WINE COOLER, DOLCE STIL NOVO, BLACK, COPPER, BUILT-IN

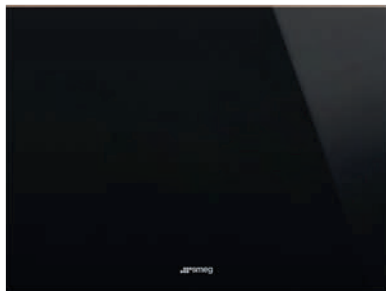

PLUS:



Copper

Max Capacity (bottles 0,75lt): 21

Functions display: Temperature alarm, Temperature value

Noise level: 36 dB(A) re 1pW

Touch control

45 cm

Door opening type: With push pull system
Anti-UV door glass

Led

Number of removable shelves: 2

Removable shelves on telescopic guide rails

Number of fixed shelves: 1

Adjustable temperature zones: 1

Type of temperature control: Electronic

Temperature range: 5-20 °C

Temperature Alarm

Door open alarm

Control lock

Activated charcoal filter

Integrated heating element

Number of compressors: 1

Compressor type: Low vibration compressor

Defrost: Automatic

Current: 0.4 A

Frequency (Hz): 50 Hz

Voltage (V): 220-240 V

Hinge position: Right

CVI629NR3

WINE COOLER, DOLCE STIL NOVO, BLACK, COPPER, BUILT-IN



PLUS:



Copper

Max Capacity (bottles 0,75lt): 29

Functions display: Temperature alarm, Temperature value

Noise level: 38 dB(A) re 1pW

Touch control

60 cm

Door opening type: With push pull system
Anti-UV door glass

Led

Number of removable shelves: 2

Removable shelves on telescopic guide rails

Number of fixed shelves: 1

Adjustable temperature zones: 2

Type of temperature control: Electronic

Temperature range: 5-20 °C

Temperature Alarm

Door open alarm

Control lock

Activated charcoal filter

Integrated heating element

Number of compressors: 1

Compressor type: Low vibration compressor

Defrost: Automatic

Current: 0.4 A

Frequency (Hz): 50 Hz

Voltage (V): 220-240 V

Hinge position: Right

CPS615NR

DRAWER, SOMMELIER, DOLCE STIL NOVO, 15 CM, BLACK, COPPER



Front panel: With horizontal strip

Eclipse

Copper

Opening mechanism: Push-pull

Max weight allowance: 15 kg

15 cm

Accessories included: Slavonia durmast wooden shelf, Wine pump, 2 corks, Sparkling wines cork, Cork to pour wine, Anti-drip cork, Solid steel cork for sparkling wines, Champagne/ sparkling wine pliers, Corkscrew sommelier, Red wines cork, Wine thermometer with slipcase, Wine funnel with wooden handle

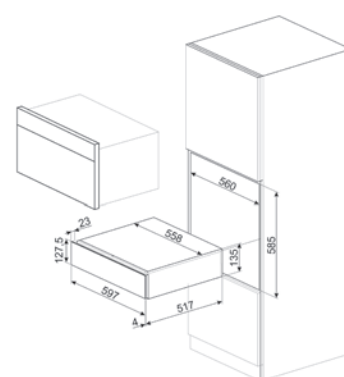
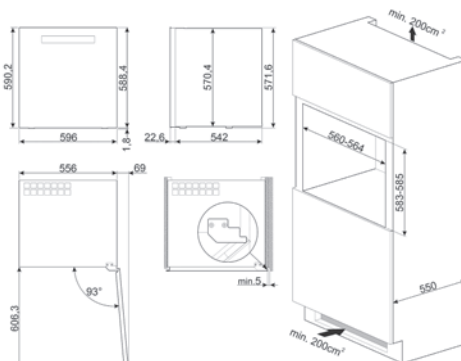
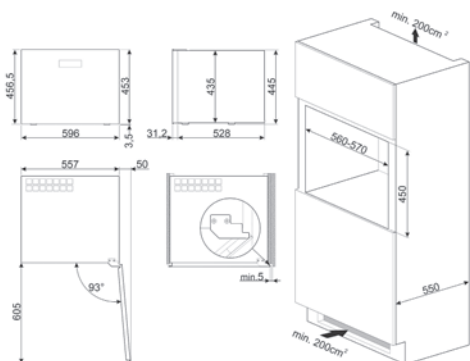



CVI638RN3

WINE COOLER, DOLCE STIL NOVO, BLACK, BUILT-IN



PLUS:



Max Capacity (bottles 0,75lt): 38

Functions display: Temperature alarm,
Temperature value
Noise level: 38 dB(A) re 1pW
Touch control

82-87 cm

Door opening type: With handle
Anti-UV door glass
Led
Number of removable shelves: 3
Removable shelves on telescopic guide rails
Number of fixed shelves: 2
Adjustable temperature zones: 2
Type of temperature control: Electronic
Temperature range: 5-20 °C
Temperature Alarm
Door open alarm
Control lock
Activated charcoal filter
Integrated heating element
Number of compressors: 1
Compressor type: Low vibration compressor
Adjustable feet: 2 Front + 2 Rear
Defrost: Automatic

Current: 0.4 A
Frequency (Hz): 50 Hz
Voltage (V): 220-240 V

Hinge position: Right

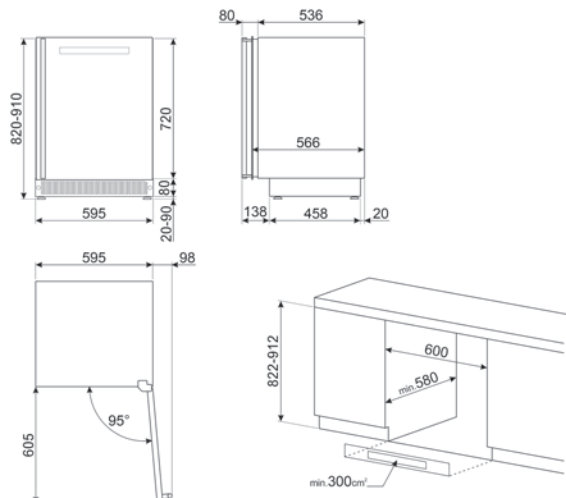

CVI638LN3

WINE COOLER, DOLCE STIL NOVO, BLACK, BUILT-IN



Hinge position: Left



KS905NXE2

KS905NXE2

DECORATIVE WALL HOOD, LINEA, 90 CM, BLACK



PLUS:



No. of speeds	I	II	III	INT
Extraction rate IEC 61591 m ³ /h	320	401	564	767
Noise level IEC 60704-2-13 dB(A)	50	61	65	73

Motor power: 275 W
 Free outlet maximum capacity: 820 m³/h
 Black
 Electronic control
 Touch control
 No. of speeds: 3
 Intensive speed
 Time-setting options
 3 aluminium grease filters
 Vent outlet: 150 mm
 Non return valve
 2 led lamps (1 W)
 Fluid Dynamic Efficiency class (FDEC): A
 Lighting Efficiency Class (LEC): A
 Grease Filtering Efficiency Class (GFEC): C
 Sound power level at highest setting (Lwa): 65 dB(A)

Frequency (Hz): 50-60 Hz
 Voltage: 220-240 V

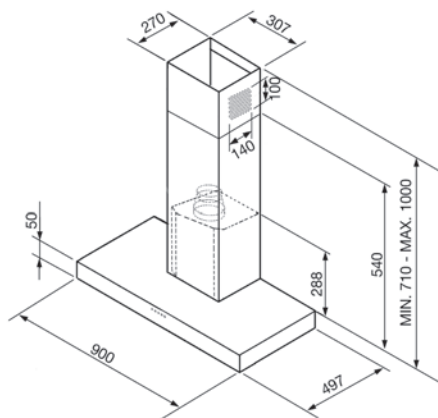

KI90XE

DECORATIVE ISLAND HOOD, LINEA, 90 CM, BLACK



PLUS:



No. of speeds	I	II	III	INT
Extraction rate IEC 61591 m ³ /h	266	385	469	703
Noise level IEC 60704-2-13 dB(A)	49	59	61	70

Motor power: 275 W
 Free outlet maximum capacity: 820 m³/h
 Electronic control
 Touch control
 No. of speeds: 3
 Intensive speed
 3 aluminium grease filters
 Vent outlet: 150 mm
 Non return valve
 4 led lamps (1 W)
 Fluid Dynamic Efficiency class (FDEC): B
 Lighting Efficiency Class (LEC): A
 Grease Filtering Efficiency Class (GFEC): C
 Sound power level at highest setting (Lwa): 61 dB(A)

Frequency (Hz): 50-60 Hz
 Voltage: 220-240 V

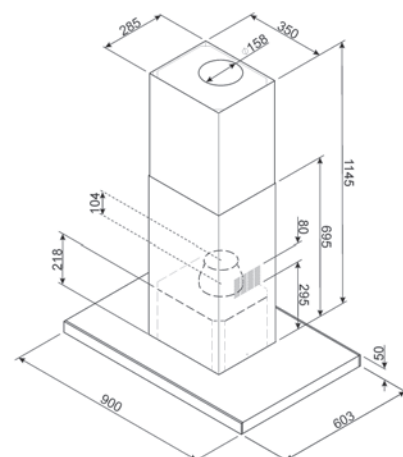



SO6104APB3

SO6104APB3

COMBINATION MULTITECH OVEN, VAPOR CLEAN, LINEA, 60CM, BLACK



PLUS:

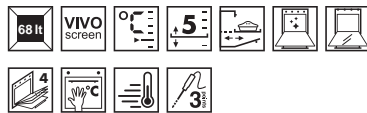

FUNCTIONS:

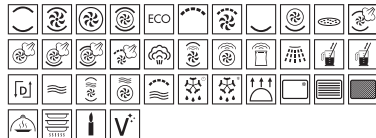

Gross volume: 79 l
 Net volume of the cavity: 68 l
 Automatic programmes: 150
 Customisable recipes: 10
 Display: 04 - 03
 Display technology: TFT
 Delay start and automatic end cooking
 Door opening type: Standard opening
 Minute minder: Yes
 Timer: Electronic
 End of cooking acoustic alarm
 Temperature control: Electronic
 Heating suspended when door is opened
 Temperatures: from 30°C to 250°C
 Soft Close hinges
 Clear
 Light when door is opened

Nominal power: 3000 W
 Microwave effective power: 900 W

Frequency (Hz): 50/60 Hz
 Current: 13 A
 Voltage: 220-240 V

ACCESSORIES INCLUDED:

Insert grid: 1
 Temperature probe
 St/steel perforated deep tray (40mm): 1
 St/steel tray (20mm): 1
 Telescopic Guide rails, total Extraction: 1

SO6104S4PB3

COMBINATION STEAM OVEN, VAPOR CLEAN, LINEA, 60CM, BLACK



PLUS:

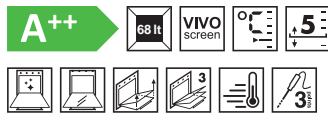

FUNCTIONS:

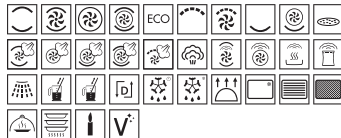

Gross volume: 79 l
 Net volume of the cavity: 68 l
 Automatic programmes: 150
 Customisable recipes: 10
 Display: 04 - 03
 Display technology: TFT
 Delay start and automatic end cooking
 Door opening type: Standard opening
 Minute minder: Yes
 Timer: Electronic
 End of cooking acoustic alarm
 Temperature control: Electronic
 Heating suspended when door is opened
 Temperatures: from 30°C to 250°C
 Soft Close hinges
 Clear
 Light when door is opened
 2 halogen lamps (40 W)

Nominal power: 3000 W
 Energy consumption per cycle in conventional mode: 1.09 kWh
 Energy consumption in conventional mode: 3.92 MJ
 Energy consumption per cycle in fan-forced convection: 0.51 kWh
 Energy consumption in forced air convection: 1.84 MJ

Frequency (Hz): 50/60 Hz
 Current: 13 A
 Voltage: 220-240 V

ACCESSORIES INCLUDED:

Insert grid: 1
 Temperature probe
 St/steel perforated deep tray (40mm): 1
 St/steel tray (20mm): 1

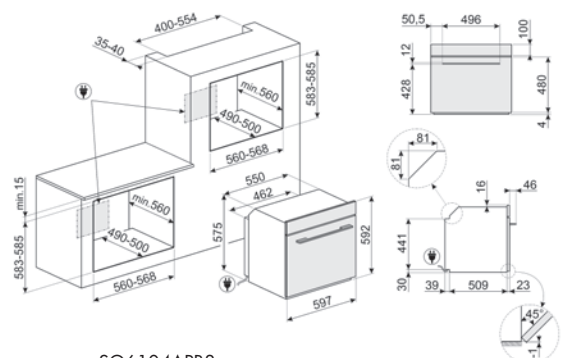

SO6104APB3
 SO6104S4PB3

SF6101TB3

THERMO-VENTILATED OVEN, VAPOR CLEAN, LINEA, 60CM, BLACK



PLUS:

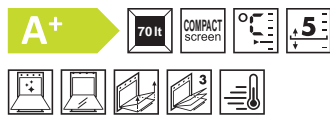

FUNCTIONS:



Gross volume: 79 l
 Net volume of the cavity: 70 l
 Display: 01
 Display technology: LCD
 Delay start and automatic end cooking
 Door opening type: Standard opening
 Minute minder: Yes
 Timer: Electronic
 End of cooking acoustic alarm
 Temperature control: Electronic
 Heating suspended when door is opened
 Temperatures: from 30°C to 280°C
 Clear
 Light when door is opened
 1 halogen lamp (40 W)
 Tilting grill

Nominal power: 3000 W
 Energy consumption per cycle in conventional mode: 1.13 KWh
 Energy consumption in conventional mode: 4.07 MJ
 Energy consumption per cycle in fan-forced convection: 0.68 KWh
 Energy consumption in forced air convection: 2.45 MJ

Frequency (Hz): 50/60 Hz
 Current: 13 A
 Voltage: 220-240 V

ACCESSORIES INCLUDED:

Enamelled deep tray (40mm): 1
 Insert grid: 1
 Rack with back stop: 1

SO6102TB3

THERMO-VENTILATED OVEN, VAPOR CLEAN, LINEA, 60CM, BLACK



PLUS:

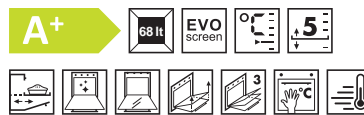

FUNCTIONS:



Gross volume: 78 l
 Net volume of the cavity: 68 l
 Display: 02
 Display technology: LCD
 Delay start and automatic end cooking
 Door opening type: Standard opening
 Minute minder: Yes
 Timer: Electronic
 End of cooking acoustic alarm
 Temperature control: Electronic
 Heating suspended when door is opened
 Temperatures: from 30°C to 280°C
 Soft Close hinges
 Clear
 Light when door is opened
 2 halogen lamps (40 W)

Nominal power: 3000 W
 Energy consumption per cycle in conventional mode: 1.15 KWh
 Energy consumption in conventional mode: 4.14 MJ
 Energy consumption per cycle in fan-forced convection: 0.68 KWh
 Energy consumption in forced air convection: 2.45 MJ

Frequency (Hz): 50/60 Hz
 Current: 13 A
 Voltage: 220-240 V

ACCESSORIES INCLUDED:

Enamelled tray (20mm): 1
 Insert grid: 1
 Rack with back stop: 1
 Telescopic Guide rails, partial Extraction: 1

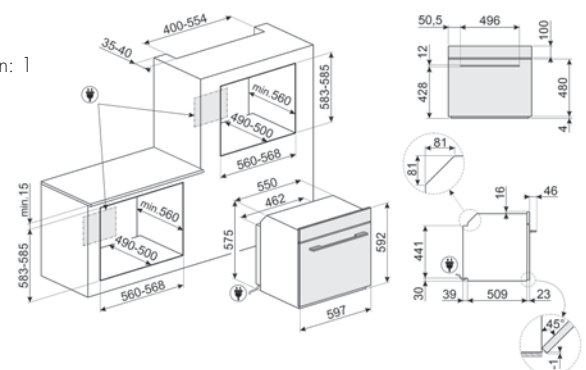

SF6101TB3
 SO6102TB3

SF6100VB3

THERMO-VENTILATED OVEN, PYROLITIC,
LINEA, 60CM, BLACK



PLUS:

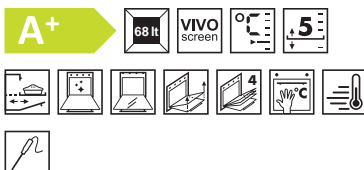

FUNCTIONS:



Gross volume: 78 l
 Net volume of the cavity: 68 l
 Automatic programmes: 150
 Customisable recipes: 10
 Display: 04 - 03
 Display technology: TFT
 Delay start and automatic end cooking
 Door opening type: Standard opening
 Minute minder: Yes
 Timer: Electronic
 End of cooking acoustic alarm
 Temperature control: Electronic
 Heating suspended when door is opened
 Door Lock During Pyrolysis
 Temperatures: from 30°C to 280°C
 Soft Close hinges
 Clear
 Light when door is opened
 2 halogen lamps (40 W)

Nominal power: 3000 W
 Energy consumption per cycle in conventional mode: 1.09 KWh
 Energy consumption in conventional mode: 3.92 MJ
 Energy consumption per cycle in fan-forced convection: 0.68 KWh
 Energy consumption in forced air convection: 2.45 MJ

Frequency (Hz): 50/60 Hz
 Current: 13 A
 Voltage: 220-240 V

ACCESSORIES INCLUDED:

Enamelled tray (20mm): 1
 Insert grid: 1
 Temperature probe
 Telescopic Guide rails, total Extraction: 1

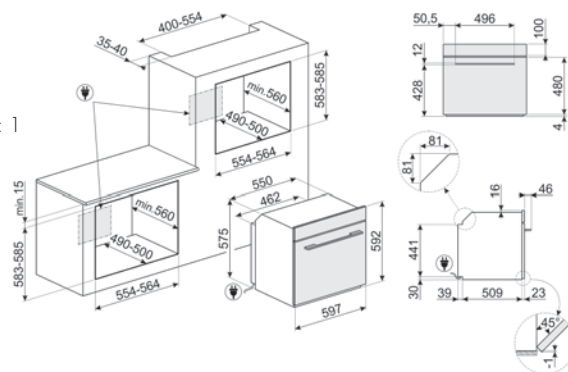

SF6100VB3

SO4104S4PB3

COMBINATION STEAM OVEN, VAPOR CLEAN, LINEA, 45 CM, BLACK



PLUS:



FUNCTIONS:



Gross volume: 50 l
 Net volume of the cavity: 41 l
 Display: 02
 Display technology: LCD
 Delay start and automatic end cooking
 Door opening type: Standard opening
 Minute minder: Yes
 Timer: Electronic
 End of cooking acoustic alarm
 Temperature control: Electronic
 Heating suspended when door is opened
 Temperatures: from 30°C to 250°C
 Soft Close hinges
 Clear
 Light when door is opened
 1 halogen lamp (40 W)

Nominal power: 3000 W
 Energy consumption per cycle in conventional mode: 0.80 KWh
 Energy consumption in conventional mode: 2.88 MJ
 Energy consumption per cycle in fan-forced convection: 0.44 KWh
 Energy consumption in forced air convection: 1.58 MJ

Frequency (Hz): 50/60 Hz
 Current: 13 A
 Voltage: 220-240 V

ACCESSORIES INCLUDED:

Insert grid: 1
 St/steel perforated deep tray (40mm): 1
 St/steel tray (20mm): 1
 Other: water loading kit

SO4101M2PB3

COMBINATION MICROWAVE OVEN, VAPOR CLEAN, LINEA, 45 CM, BLACK



PLUS:

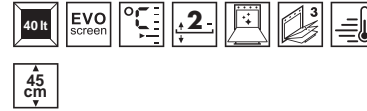

FUNCTIONS:



Gross volume: 50 l
 Net volume of the cavity: 40 l
 Display: 02
 Display technology: LCD
 Delay start and automatic end cooking
 Door opening type: Standard opening
 Minute minder: Yes
 Timer: Electronic
 End of cooking acoustic alarm
 Temperature control: Electronic
 Heating suspended when door is opened
 Temperatures: from 30°C to 250°C
 Soft Close hinges
 Clear
 Light when door is opened
 2 halogen lamps (40 W)

Nominal power: 3300 W
 Microwave screen protection
 Microwave effective power: 800 W

Frequency (Hz): 50 Hz
 Voltage: 220-240 V

ACCESSORIES INCLUDED:

Glass tray: 1
 Insert grid: 1

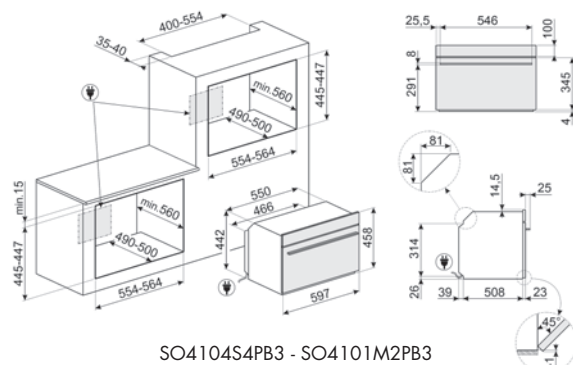

SO4104S4PB3 - SO4101M2PB3

FMI125N

MICROWAVE, BUILT-IN, LINEA, NEPTUNE
GREY



PLUS:



Microwave with grill
Automatic programmes: 8
Gross volume: 26 l
Net volume: 25 l
Stainless steel
TFT
End of cooking acoustic alarm
Door: Full glass
End cooking
Light when door is opened
Turntable dimensions: 31.5 cm
Grid: 1
Other: Suction cup
Microwave stops when door is opened
Microwave effective power: 900 W
Quartz Grill: 1 Kw
Safety Thermostat
Touch control

Frequency (Hz): 50 Hz
Current: 6.3 A
Voltage (V): 230 V

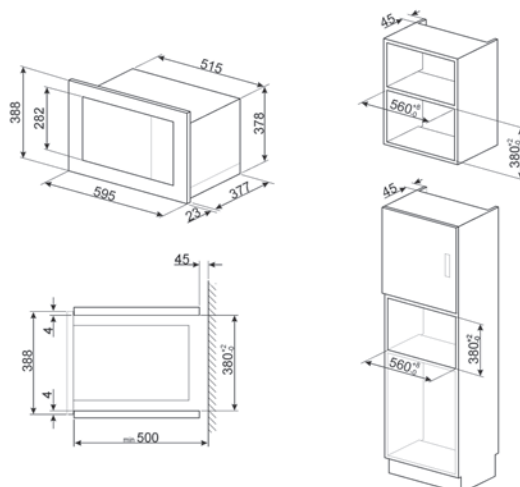

FMI125N

CMS4104B3

COFFEE MACHINE, LINEA, 45 CM
COMPACT, NEPTUNE GREY



PLUS:



Automatic Cappuccino maker with separate tank for milk

Coffee function (double)

Coffee function (single)

Variable coffee temperature: 3 levels

Variable coffee length: 5 levels

Adjustable coffee intensity: 5 levels

Hot water function: for Tea or other drinks

Ground coffee option

Steam dispenser

Thermal carafe: Yes, stainless steel 0,5 L with autoclean system

Cup holder: Yes, warmed

Programmed automatic switch-on

Removable milk jug

Adjustable cappuccino foam

At every switch on/off

Lack of water signal

Coffee granule container capacity: 350 g

Coffee granules compartment

Ground coffee compartment

Removable water container

Used coffee waste container

Drip tray

Automatic descaling

Water container capacity: 2.40 l

Water hardness

Adjustable coffee grinder

Current: 5.6 A

Frequency (Hz): 50-60 Hz

Nominal power: 1350 W

Voltage (V): 220-240 V

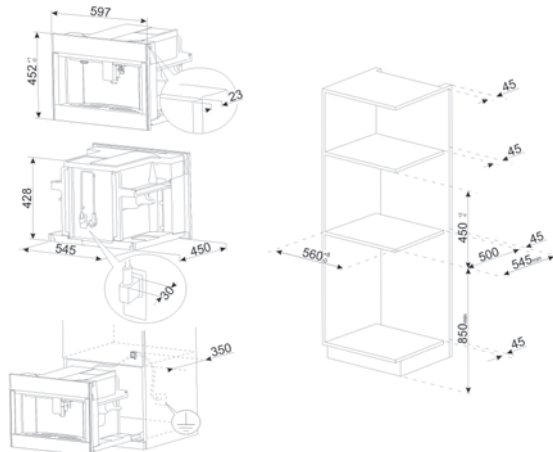

CMS4104B3

CPR115B3

DRAWER, REHEAT, LINEA, 15 CM, BLACK



Front panel: Full glass

Control knobs

Opening mechanism: Push-pull

Capacity: 21 l

Minimum temperature: 30°

Maximum temperature: 80 °C

Reheating

Defrost

Keep warm

Dish warmer

Max weight allowance: 15 kg

15 cm

Current: 2 A

Frequency (Hz): 50-60 Hz

Nominal power: 400 W

Voltage (V): 220-240 V

Accessories included: Silicone antislip mat

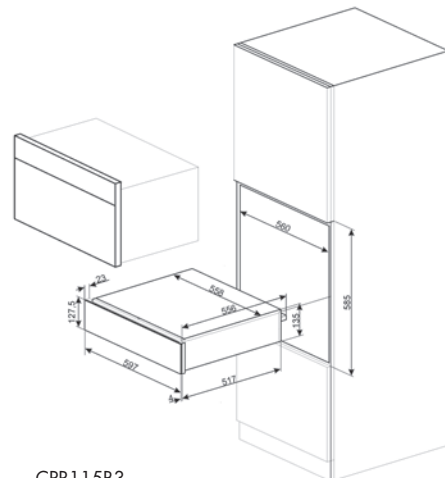

CPR115B3

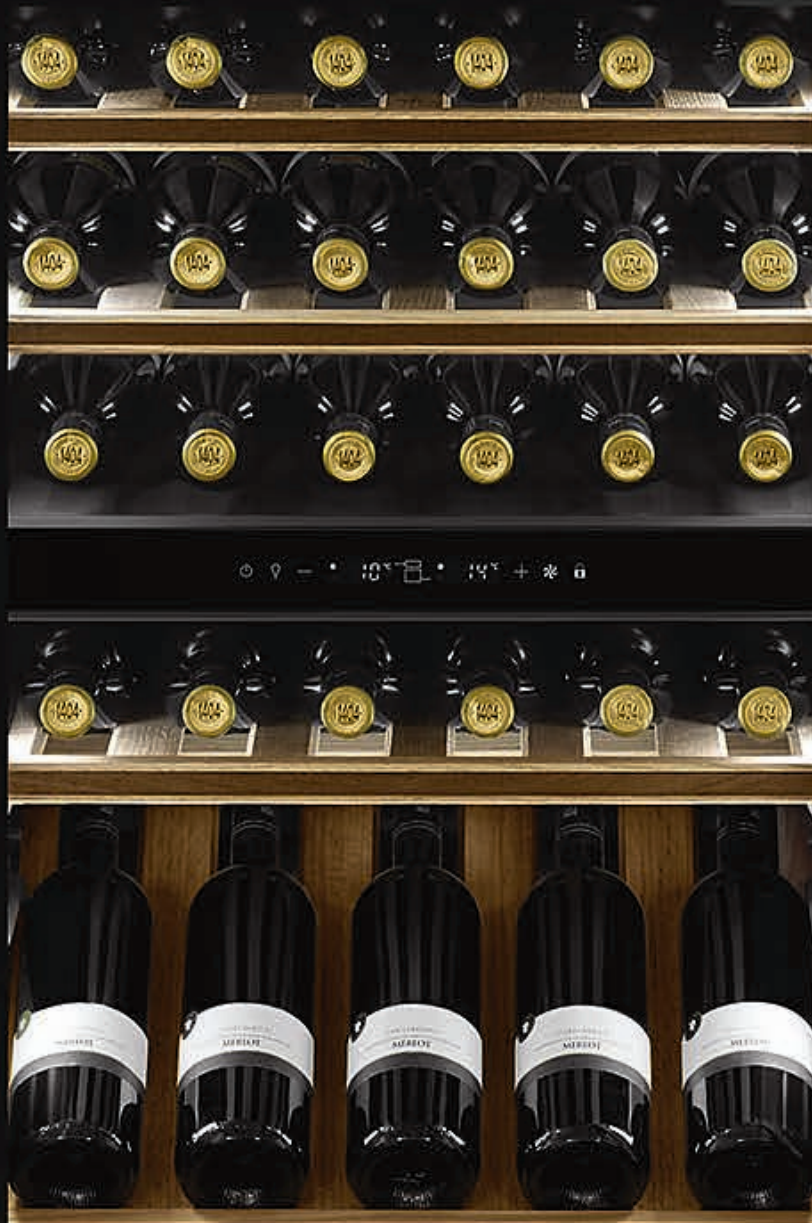

smeg

CVI040BE

CVI040BE

WINE COOLER, LINEA, BLACK, BUILT-IN



PLUS:



Max Capacity (bottles 0,75lt): 40

Functions display: Temperature alarm,
Temperature value
Noise level: 38 dB(A) re 1pW
Touch control

60 cm

Door opening type: With **E MOTION**
electronic opening system
Anti-UV door glass
Led activated with **EMOTION** system
Number of removable shelves: 4
Removable shelves on telescopic guide rails
Number of fixed shelves: 1
Adjustable temperature zones: 2
Type of temperature control: Electronic
Temperature range: 5-20 °C
Temperature Alarm
Door open alarm
Control lock
Activated charcoal filter
Integrated heating element
Number of compressors: 1
Compressor type: Low vibration compressor
Defrost: Automatic

Current: 0.4 A
Frequency (Hz): 50 Hz
Voltage (V): 220-240 V
Dimensions of the products
HxWxD (mm): 913x596x570

CVI129B3

WINE COOLER, LINEA, BLACK, BUILT-IN



PLUS:



Max Capacity (bottles 0,75lt): 29

Functions display: Temperature alarm,
Temperature value
Noise level: 38 dB(A) re 1pW
Touch control

60 cm

Door opening type: With push pull system
Anti-UV door glass
Led
Number of removable shelves: 2
Removable shelves on telescopic guide rails
Number of fixed shelves: 1
Adjustable temperature zones: 2
Type of temperature control: Electronic
Temperature range: 5-20 °C
Temperature Alarm
Door open alarm
Control lock
Activated charcoal filter
Integrated heating element
Number of compressors: 1
Compressor type: Low vibration compressor
Defrost: Automatic

Current: 0.4 A
Frequency (Hz): 50 Hz
Voltage (V): 220-240 V

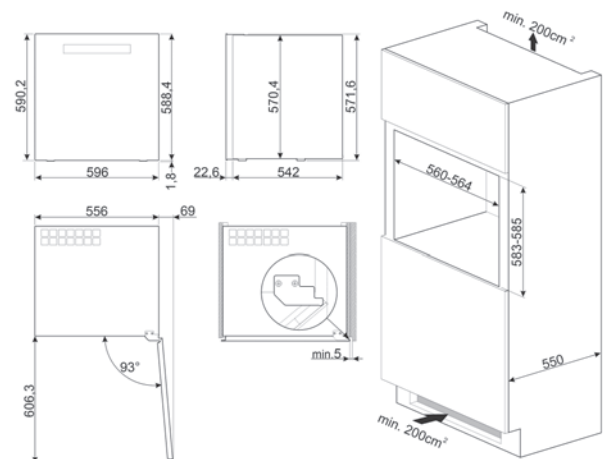

CVI129B3

CVI121B3

WINE COOLER, LINEA, BLACK, BUILT-IN



CPS115B3

DRAWER, SOMMELIER, LINEA, 15 CM, BLACK



PLUS:



Max Capacity (bottles 0,75lt): 21

Functions display: Temperature alarm,
Temperature value
Noise level: 36 dB(A) re 1pW
Touch control

45 cm

Door opening type: With push pull system
Anti-UV door glass
Led
Number of removable shelves: 2
Removable shelves on telescopic guide rails
Number of fixed shelves: 1
Adjustable temperature zones: 1
Type of temperature control: Electronic
Temperature range: 5-20 °C
Temperature Alarm
Door open alarm
Control lock
Activated charcoal filter
Integrated heating element
Number of compressors: 1
Compressor type: Low vibration compressor
Defrost: Automatic

Current: 0.4 A
Frequency (Hz): 50 Hz
Voltage (V): 220-240 V

Hinge position: Right

Opening mechanism: Push-pull

Max weight allowance: 15 kg

15 cm

Accessories included: Slavonia durmast wooden shelf, Wine pump, 2 corks, Sparkling wines cork, Cork to pour wine, Anti-drip cork, Solid steel cork for sparkling wines, Champagne/ sparkling wine pliers, Corkscrew sommelier, Red wines cork, Wine thermometer with slipcase, Wine funnel with wooden handle

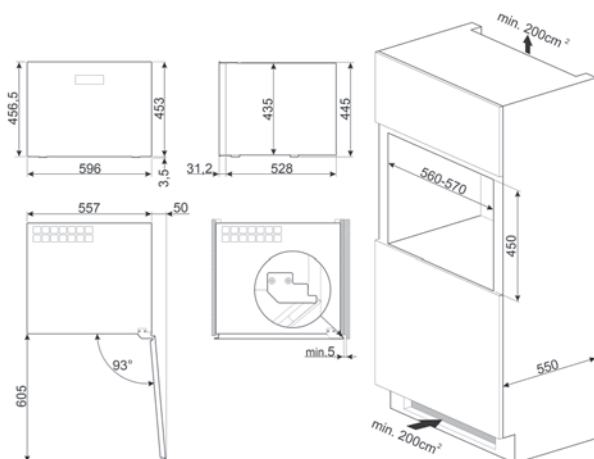

CVI121B3



SR775PO

SR775PO

GAS, HOB, CORTINA, 70/75 CM, CREAM, ANTIQUE BRASS



PLUS:



Built-in type: Traditional
 Front-left: 1.10 kW
 Rear-left: 2.60 kW
 Central: 5.00 kW
 Rear-right: 1.70 kW
 Front-right: 1.70 kW
 Cast iron
 Gas safety valves
 Control knob position: Front
 Smeg Contemporary
 Burners Material: Alluminium
 Controls colour: Cream

Voltage (V): 220-240 V
 Frequency (Hz): 50/60 Hz
 Electrical connection rating (W): 1 W

SR764PO

GAS, HOB, CORTINA, 60 CM, CREAM, ANTIQUE BRASS



PLUS:



Built-in type: Traditional
 Left: 3.90 kW
 Rear-centre: 1.70 kW
 Front-centre: 1.10 kW
 Right: 2.60 kW
 Cast iron
 Gas safety valves
 Control knob position: Front
 Smeg Contemporary
 Burners Material: Alluminium
 Controls colour: Cream

Voltage (V): 220-240 V
 Frequency (Hz): 50/60 Hz
 Electrical connection rating (W): 1 W

SR775AO

GAS, HOB, CORTINA, 70/75 CM, ANTHRACITE, ANTIQUE BRASS

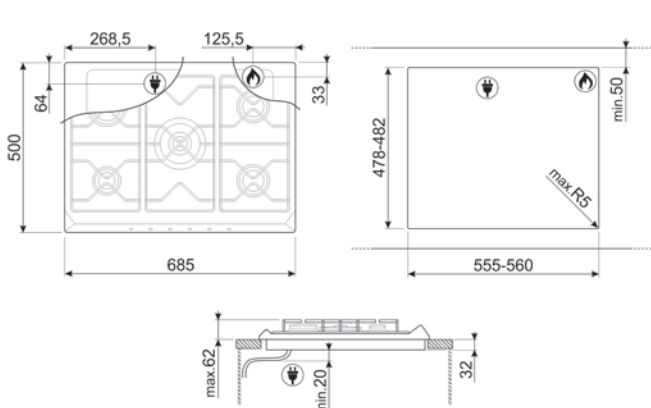

SR764AO

GAS, HOB, CORTINA, 60 CM, ANTHRACITE, ANTIQUE BRASS

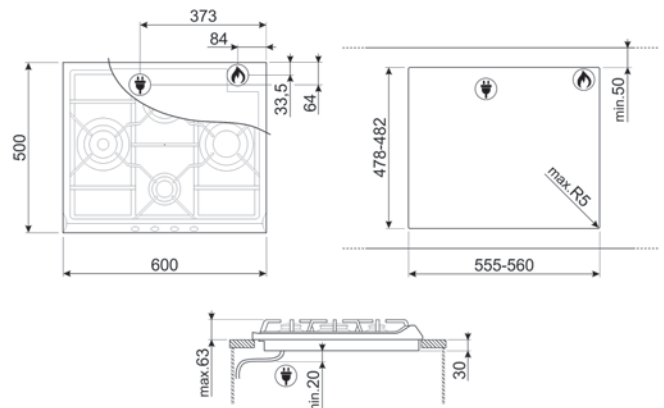



KCI19POE

DECORATIVE ISLAND HOOD, CORTINA, 90 CM, CREAM, ANTIQUE BRASS



PLUS:



No. of speeds	I	II	III	INT
Extraction rate IEC 61591 m ³ /h	321	385	549	796
Noise level IEC 60704-2-13 dB(A)	47	59	61	70

Motor power: 275 W
 Free outlet maximum capacity: 820 m³/h
 Control knobs: Cortina
 Control knobs
 No. of speeds: 3
 Intensive speed
 3 aluminium grease filters
 Vent outlet: 150 mm
 Non return valve
 4 led lamps (1 W)
 Fluid Dynamic Efficiency class (FDEC): A
 Lighting Efficiency Class (LEC): A
 Grease Filtering Efficiency Class (GFEC): C
 Sound power level at highest setting (Lwa): 61 dB(A)

Frequency (Hz): 50-60 Hz
 Voltage: 220-240 V

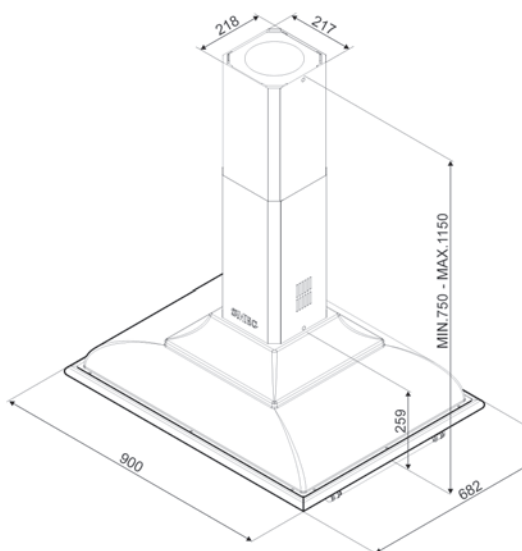

KCI19POE

DECORATIVE WALL HOOD, CORTINA, 90 CM, CREAM, ANTIQUE BRASS



PLUS:



No. of speeds	I	II	III	INT
Extraction rate IEC 61591 m ³ /h	326	439	549	794
Noise level IEC 60704-2-13 dB(A)	50	57	62	71

Motor power: 275 W
 Free outlet maximum capacity: 820 m³/h
 Control knobs: Cortina
 Control knobs
 No. of speeds: 3
 Intensive speed
 3 aluminium grease filters
 Vent outlet: 150 mm
 Non return valve
 2 led lamps (1 W)
 Fluid Dynamic Efficiency class (FDEC): A
 Lighting Efficiency Class (LEC): A
 Grease Filtering Efficiency Class (GFEC): C
 Sound power level at highest setting (Lwa): 62 dB(A)

Frequency (Hz): 50-60 Hz
 Voltage: 220-240 V

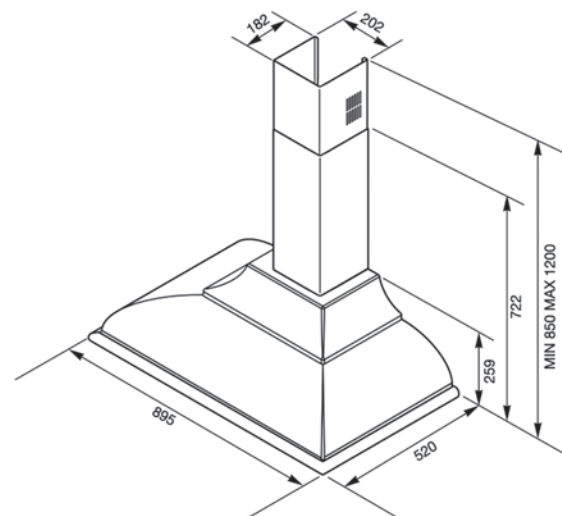

KCI19AOE

DECORATIVE ISLAND HOOD, CORTINA, 90 CM, ANTHRACITE, ANTIQUE BRASS



PLUS:



No. of speeds	I	II	III	INT
Extraction rate IEC 61591 m ³ /h	321	385	549	796
Noise level IEC 60704-2-13 dB(A)	47	59	61	70

Motor power: 275 W
 Free outlet maximum capacity: 820 m³/h
 Control knobs: Cortina
 Control knobs
 No. of speeds: 3
 Intensive speed
 3 aluminium grease filters
 Vent outlet: 150 mm
 Non return valve
 4 led lamps (1 W)
 Fluid Dynamic Efficiency class (FDEC): A
 Lighting Efficiency Class (LEC): A
 Grease Filtering Efficiency Class (GFEC): C
 Sound power level at highest setting (Lwa): 61 dB(A)

Frequency (Hz): 50-60 Hz
 Voltage: 220-240 V

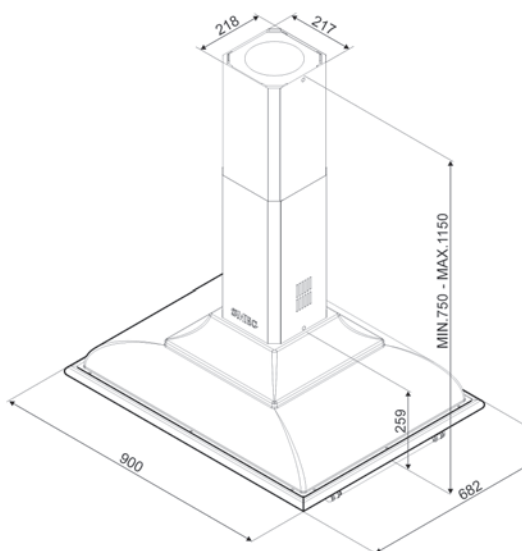

KCI19AOE

DECORATIVE WALL HOOD, CORTINA, 90 CM, ANTHRACITE, ANTIQUE BRASS



PLUS:



No. of speeds	I	II	III	INT
Extraction rate IEC 61591 m ³ /h	326	439	549	794
Noise level IEC 60704-2-13 dB(A)	50	57	62	71

Motor power: 275 W
 Free outlet maximum capacity: 820 m³/h
 Control knobs: Cortina
 Control knobs
 No. of speeds: 3
 Intensive speed
 3 aluminium grease filters
 Vent outlet: 150 mm
 Non return valve
 2 led lamps (1 W)
 Fluid Dynamic Efficiency class (FDEC): A
 Lighting Efficiency Class (LEC): A
 Grease Filtering Efficiency Class (GFEC): C
 Sound power level at highest setting (Lwa): 62 dB(A)

Frequency (Hz): 50-60 Hz
 Voltage: 220-240 V

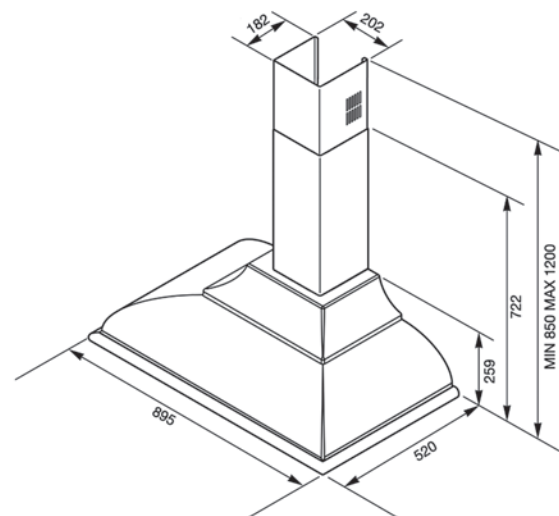



SMEG

SF700PO

ELECTRIC VENTILATED OVEN, CORTINA, 60CM, CREAM, ANTIQUE BRASS



PLUS:

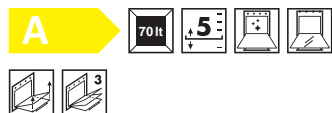

FUNCTIONS:



Antique brass

Gross volume: 79 l
 Net volume of the cavity: 70 l
 Control knobs
 Automatic end cooking
 Minute minder: Yes
 Timer: Electro-mechanical
 End of cooking acoustic alarm
 Temperature control: Electro-mechanical
 Temperatures: from 50°C to 250°C
 Clear
 1 halogen lamp (40 W)

Nominal power: 3000 W
 Energy consumption per cycle in conventional mode: 1.15 kWh
 Energy consumption in conventional mode: 4.14 MJ
 Energy consumption per cycle in fan-forced convection: 0.80 kWh
 Energy consumption in forced air convection: 2.88 MJ

Frequency (Hz): 50 Hz
 Current: 13 A
 Voltage: 220-240 V

ACCESSORIES INCLUDED:

Enamelled deep tray (40mm): 1
 Rack with back stop: 1

MP722PO

MICROWAVE, BUILT-IN, CORTINA, CREAM, COMPONENTS FINISHING: ANTIQUE BRASS



PLUS:



Microwave with grill
 Gross volume: 23 l
 Net volume: 22 l
 Stainless steel
 Components finishing: Antique brass
 1 a LED
 End of cooking acoustic alarm
 Showroom demo option
 Tilting grill
 Door: With panel
 2 Cream Knobs
 Start and stop
 Ceramic base
 1 incandescent light of 20 W
 Light when door is opened
 Grid: 1
 Microwave stops when door is opened
 Microwave screen protection
 Microwave effective power: 850 W
 Safety Thermostat
 Control knobs

Frequency (Hz): 50 Hz
 Current: 11 A
 Voltage (V): 220-240 V

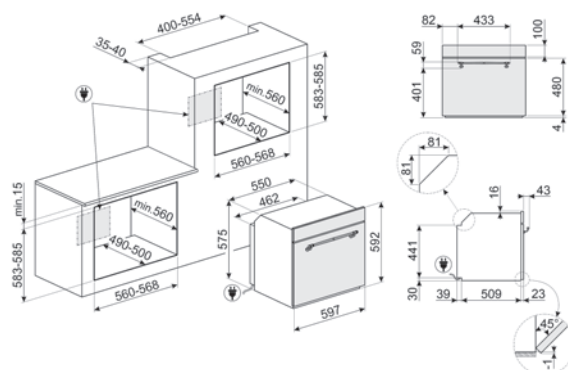
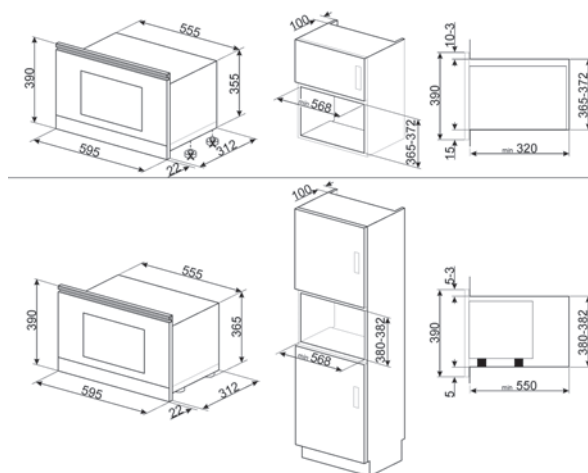

SF700AO

ELECTRIC VENTILATED OVEN, CORTINA, 60CM, ANTHRACITE, ANTIQUE BRASS



PLUS:



FUNCTIONS:



Antique brass

Gross volume: 79 l
 Net volume of the cavity: 70 l
 Control knobs
 Automatic end cooking
 Minute minder: Yes
 Timer: Electro-mechanical
 End of cooking acoustic alarm
 Temperature control: Electro-mechanical
 Temperatures: from 50°C to 250°C
 Clear
 1 halogen lamp (40 W)

Nominal power: 3000 W
 Energy consumption per cycle in conventional mode: 1.15 kWh
 Energy consumption in conventional mode: 4.14 MJ
 Energy consumption per cycle in fan-forced convection: 0.80 kWh
 Energy consumption in forced air convection: 2.88 MJ

Frequency (Hz): 50 Hz
 Current: 13 A
 Voltage: 220-240 V

ACCESSORIES INCLUDED:

Enamelled deep tray (40mm): 1
 Rack with back stop: 1

MP722AO

MICROWAVE, BUILT-IN, CORTINA, ANTHRACITE, COMPONENTS FINISHING: ANTIQUE BRASS



PLUS:



Microwave with grill
 Gross volume: 23 l
 Net volume: 22 l
 Stainless steel
 Components finishing: Antique brass
 1 a LED
 End of cooking acoustic alarm
 Showroom demo option
 Tilting grill
 Door: With panel
 2 Cream Knobs
 Start and stop
 Ceramic base
 1 incandescent light of 20 W
 Light when door is opened
 Grid: 1
 Microwave stops when door is opened
 Microwave screen protection
 Microwave effective power: 850 W
 Safety Thermostat
 Control knobs

Frequency (Hz): 50 Hz
 Current: 11 A
 Voltage (V): 220-240 V

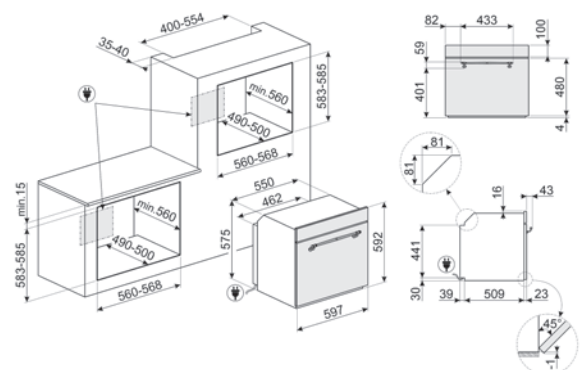
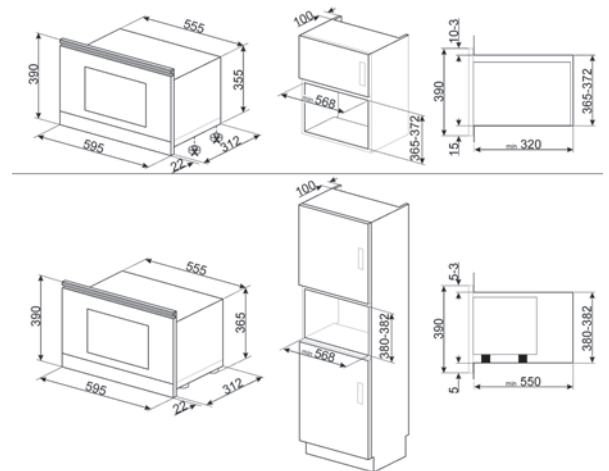



PM3643D

MIXED, HOB, CLASSICA, 65 CM, BLACK, MULTIZONE OPTION



PLUS:

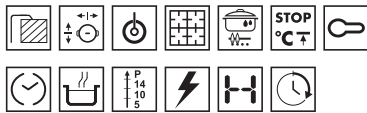

MultiZone

Built-in type: Ultra-low profile
 No. of induction cook zones: 2
 Front-left: 1.10 kW
 Rear-left: 3.10 kW
 Rear-right: 24.0x18.0 cm, 2.10 kW - 2.5 kW
 3rd zone booster power: 2.5 kW
 Front-right: 24.0x18.0 cm, 2.10 kW - 2.5 kW
 4th zone booster power: 2.5 kW
 Power levels: 9
 Right Multizone dimension: 38.5x23.0 cm
 Bridge option: Yes
 Cast iron
 Rapid level selection
 Automatic setting according to pan dimension
 pan detection: Yes
 Automatic switch off when overheat
 Automatic switch off when overflow
 Protection against accidental start up
 Gas safety valves
 Straight edge
 Control knob position: Front
 Smeg Contemporary
 Burners Material: Brass
 Controls colour: Steel effect
 Control Lock / Child Safety

Voltage (V): 220-240 V
 Voltage 2 (V): 380-415 V
 Frequency (Hz): 50/60 Hz
 Current: 16 A
 Electrical connection rating (W): 3700 W

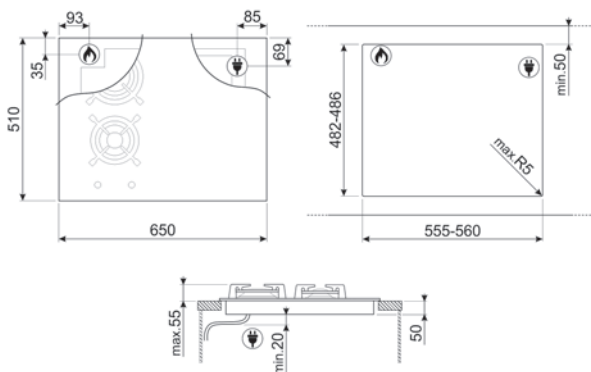

PM3953D

MIXED, HOB, CLASSICA, 90 CM, BLACK, MULTIZONE OPTION



PLUS:

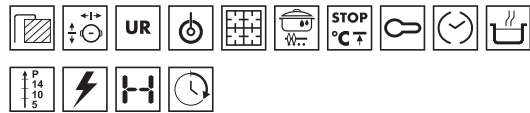

MultiZone

Built-in type: Traditional
 No. of induction cook zones: 4
 Centre-left: 6.00 kW
 Rear-centre: 24.0x18.0 cm, 2.10 kW - 2.5 kW
 2nd zone booster power: 2.5 kW
 Front-centre: 24.0x18.0 cm, 2.10 kW - 2.5 kW
 3rd zone booster power: 2.5 kW
 Rear-right: 24.0x18.0 cm, 2.10 kW - 2.5 kW
 4th zone booster power: 2.5 kW
 Front-right: 24.0x18.0 cm, 2.10 kW - 2.5 kW
 5th zone booster power: 2.5 kW
 Power levels: 9
 Central Multizone dimension: 38.5x23.0 cm
 Right Multizone dimension: 38.5x23.0 cm
 Bridge option: Yes
 Cast iron
 Rapid level selection
 Automatic setting according to pan dimension
 pan detection: Yes
 Automatic switch off when overheat
 Automatic switch off when overflow
 Protection against accidental start up
 Gas safety valves
 Straight edge
 Control knob position: Front
 Smeg Contemporary
 Burners Material: Brass
 Controls colour: Steel effect
 Control Lock / Child Safety

Voltage (V): 220-240 V
 Voltage 2 (V): 380-415 V
 Frequency (Hz): 50/60 Hz
 Current: 33 A
 Electrical connection rating (W): 7400 W

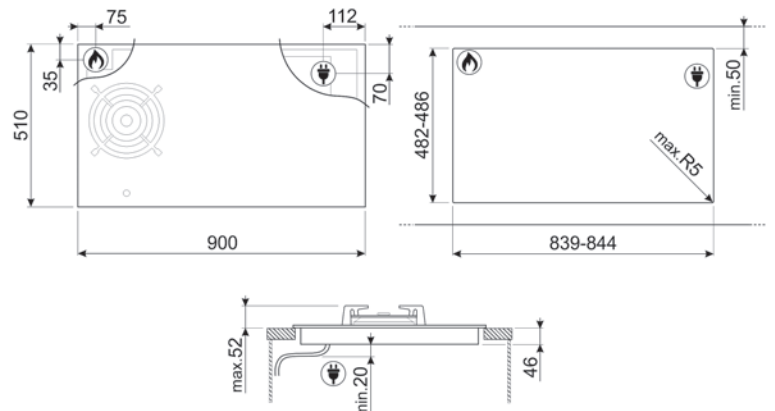

PV364LCN

GAS, HOB, CLASSICA, 65 CM, BLACK



PLUS:



Built-in type: Ultra-low profile or Fully Flushed
 Left: 3.00 kW
 Rear-centre: 1.70 kW
 Front-centre: 1.10 kW
 Right: 2.60 kW
 Cast iron
 Gas safety valves
 Ceramic glass
 Straight edge
 Control knob position: Front
 Smeg Contemporary
 Burners Material: Brass
 Burner Coating: Nichelato
 Controls colour: Steel effect

Voltage (V): 220-240 V
 Frequency (Hz): 50/60 Hz
 Electrical connection rating (W): 1 W

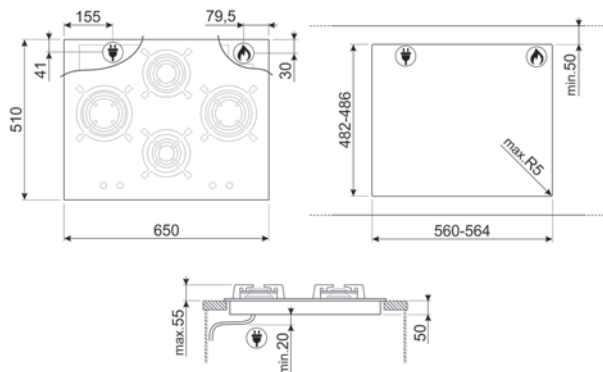

PV395LCN

GAS, HOB, CLASSICA, 90 CM, BLACK



PLUS:



Built-in type: Ultra-low profile or Fully Flushed
 Left: 6.00 kW
 Rear-centre: 1.70 kW
 Front-centre: 1.70 kW
 Rear-right: 2.60 kW
 Front-right: 1.10 kW
 Cast iron
 Gas safety valves
 Ceramic glass
 Straight edge
 Control knob position: Front
 Smeg Contemporary
 Burners Material: Brass
 Burner Coating: Nichelato
 Controls colour: Steel effect

Voltage (V): 220-240 V
 Frequency (Hz): 50/60 Hz
 Electrical connection rating (W): 1 W

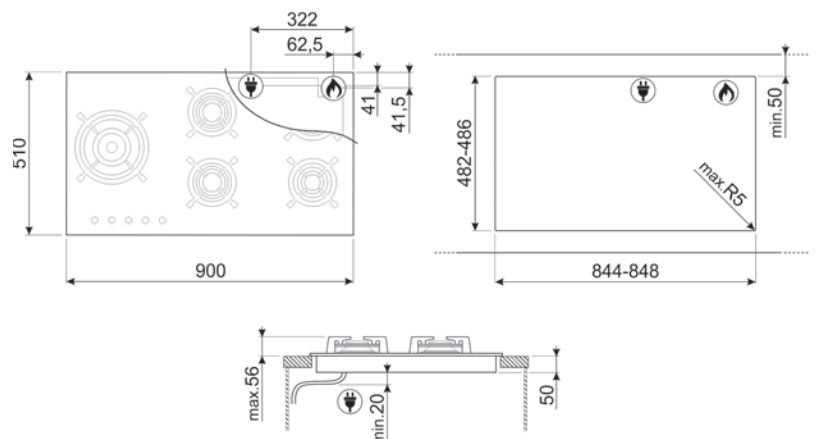

PGF95-4

GAS, HOB, CLASSICA, 90 CM, STAINLESS STEEL



PLUS:



Built-in type: Ultra-low profile

Front-left: 1.75 kW

Rear-left: 1.75 kW

Central: 3.90 kW

Rear-right: 1.75 kW

Front-right: 1.05 kW

Cast iron

Gas safety valves

Control knob position: Lateral

Standard

Burners Material: Alluminium

Controls colour: Steel effect

Voltage (V): 220-240 V

Frequency (Hz): 50/60 Hz

Electrical connection rating (W): 1 W

PGF962

GAS, HOB, CLASSICA, 90 CM, STAINLESS STEEL



PLUS:



Built-in type: Ultra-low profile

Front-left: 4.20 kW

Rear-left: 1.05 kW

Front-centre: 1.05 kW

Rear-centre: 1.75 kW

Front-right: 4.20 kW

Rear-right: 1.75 kW

Cast iron

Gas safety valves

Control knob position: Front

Standard

Burners Material: Alluminium

Controls colour: Steel effect

Voltage (V): 220-240 V

Frequency (Hz): 50/60 Hz

Electrical connection rating (W): 1 W

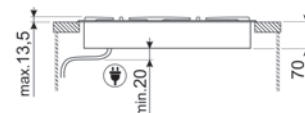
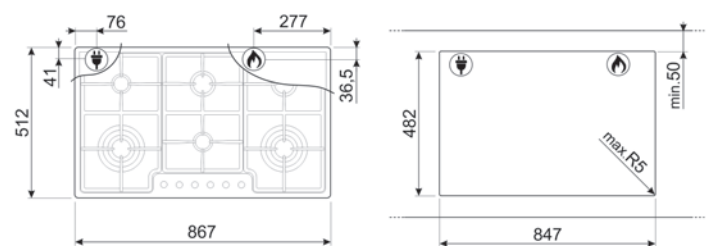
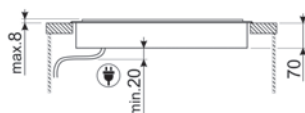
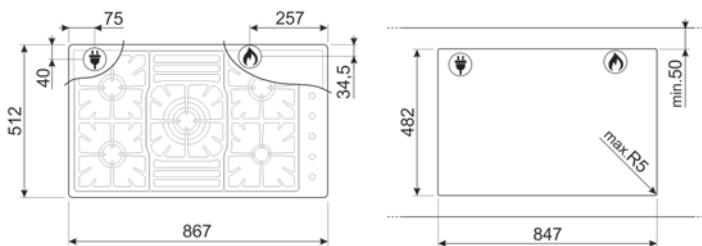

PGF64-4

GAS, HOB, CLASSICA, 60 CM, STAINLESS STEEL



PLUS:



Built-in type: Ultra-low profile
 Left: 3.90 kW
 Rear-centre: 1.05 kW
 Front-centre: 1.05 kW
 Right: 2.50 kW
 Cast iron
 Gas safety valves
 Control knob position: Front
 Standard
 Burners Material: Alluminium
 Controls colour: Steel effect

Voltage (V): 220-240 V
 Frequency (Hz): 50/60 Hz
 Electrical connection rating (W): 1 W

SER60SGH3

GAS, HOB, CLASSICA, 60 CM, STAINLESS STEEL



PLUS:



Built-in type: Traditional
 Left: 3.90 kW
 Rear-centre: 1.70 kW
 Front-centre: 1.10 kW
 Right: 2.60 kW
 Cast iron
 Gas safety valves
 Control knob position: Front
 Smeg Contemporary
 Burners Material: Alluminium
 Controls colour: Steel effect

Voltage (V): 220-240 V
 Frequency (Hz): 50/60 Hz
 Electrical connection rating (W): 1 W

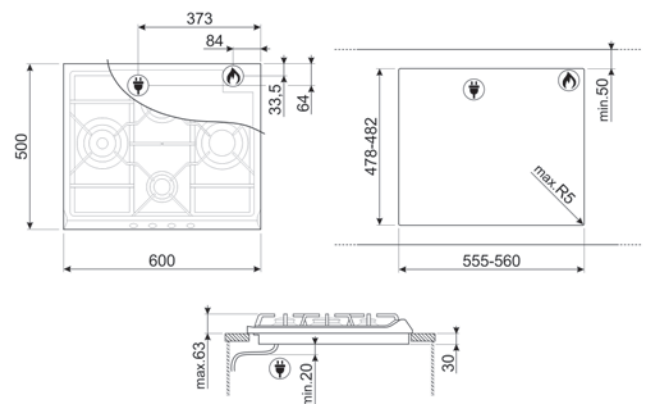
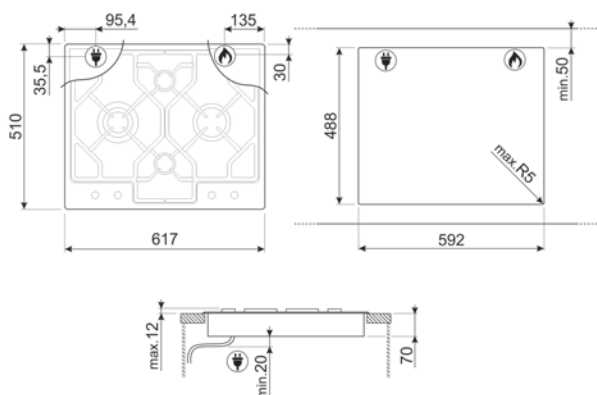



HOB472D

HOB482D2

INDUCTION WITH INTEGRATED HOOD, HOB, UNIVERSALE, 80 CM, BLACK, MULTIZONE OPTION

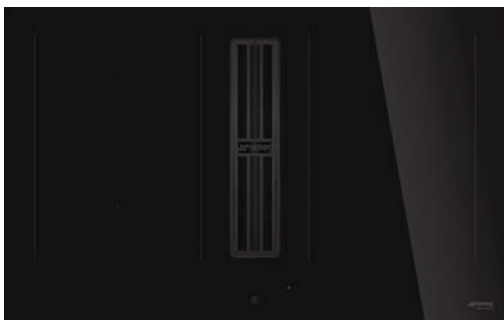

PLUS:



MultiZone

- Built-in type: Ultra-low profile or Fully Flushed
- No. of induction cook zones: 4
- Front-left: 21.0x19.0 cm, 2.10 kW - 3.00 kW
- 1st zone booster power: 3.00 kW
- Rear-left: 21.0x19.0 cm, 2.10 kW - 3.00 kW
- 2nd zone booster power: 3.00 kW
- Rear-right: 21.0x19.0 cm, 2.10 kW - 3.00 kW
- 3rd zone booster power: 3.00 kW
- Front-right: 21.0x19.0 cm, 2.10 kW - 3.00 kW
- 4th zone booster power: 3.00 kW
- Power levels: 9
- Left Multizone dimension: 39.0x21.0 cm
- Right Multizone dimension: 39.0x21.0 cm
- Cast iron
- Rapid level selection
- Automatic setting according to pan dimension
- pan detection: Yes
- Automatic switch off when overflow
- Protection against accidental start up
- Ceramic glass
- Straight edge
- Control knob position: Front
- Control lock / Child Safety

- Voltage (V): 220-240 V
- Voltage 2 (V): 380-415 V
- Frequency (Hz): 50/60 Hz
- Current: 33 A
- Electrical connection rating (W): 7620 W

ACCESSORIES INCLUDED:

Other accessories: Extraction and Filtering Kit inc tubes and Charcoal filter

HOOD

- Free outlet maximum capacity: 750 m³/h
- Motor power: 220 W
- No. of filters: 1
- Anti-grease filters: Inox
- Charcoal filters included: YES, regenerable
- Filter replacement indicator

HOOD CONTROLS

- Touch Capacitive
- Display
- Led color: Rosso

HOOD FUNCTIONS

- No. of speeds: 8
- Intensive speed: 2
- Other functions: AUTOVENT
- Delay
- Other options: Kit for Recirculation and Extraction included

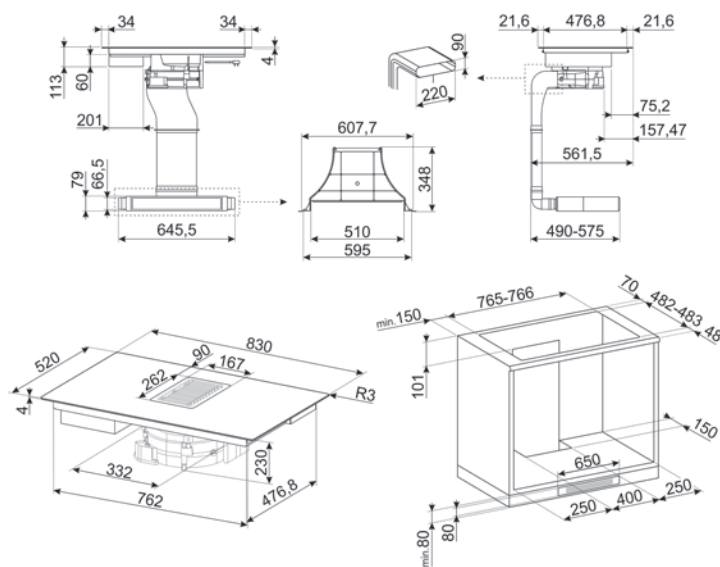

HOB472D

INDUCTION WITH INTEGRATED HOOD, HOB,
UNIVERSALE, 70 CM, BLACK, MULTIZONE OPTION



PLUS:



MultiZone

Built-in type: Ultra-low profile or Fully Flushed

No. of induction cook zones: 4

Front-left: 22.0x19.7 cm, 2.1 kW - 3 kW

1st zone booster power: 3 kW

Rear-left: 22.0x19.7 cm, 2.1 kW - 3 kW

2nd zone booster power: 3 kW

Rear-right: 22.0x19.7 cm, 2.1 kW - 3 kW

3rd zone booster power: 3 kW

Front-right: 22.0x19.7 cm, 2.1 kW - 3 kW

4th zone booster power: 3 kW

Power levels: 9

Left Multizone dimension: 39.5x22.0 cm

Right Multizone dimension: 39.5x22.0 cm

Bridge option: Yes

Enamelled flat

Rapid level selection

Automatic setting according to pan dimension

pan detection: Yes

Automatic switch off when overflow

Protection against accidental start up

Ceramic glass

Straight edge

Control knob position: Front

Control Lock / Child Safety

Voltage (V): 220-240 V

Frequency (Hz): 50/60 Hz

Current: 32 A

Electrical connection rating (W): 7620 W

ACCESSORIES INCLUDED:

Other accessories: Extraction and Filtering Kit inc tubes and Charcoal filter

HOOD

Motor power: 220 W

No. of filters: 1

Anti-grease filters: Alluminio

Charcoal filters included: YES, regenerable

Filter replacement indicator

HOOD CONTROLS

Touch Capacitive

Display

Led color: Rosso

HOOD FUNCTIONS

No. of speeds: 9

Intensive speed: 2

Other functions: AUTOVENT

Delay

Other options: Filter Kit included

Auto-Vent

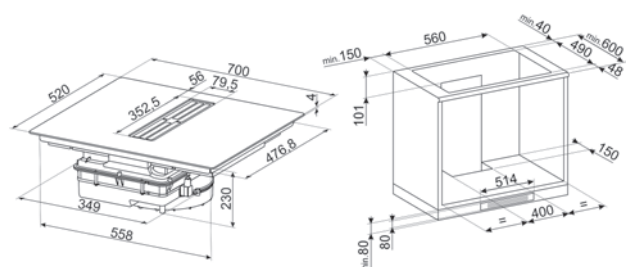
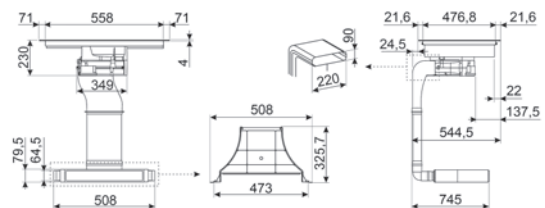

SIM3644D

INDUCTION, HOB, UNIVERSALE, 60 CM,
BLACK, MULTIZONE OPTION



PLUS:

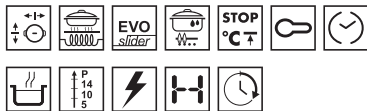

MultiZone

Built-in type: Ultra-low profile or Fully Flushed

No. of induction cook zones: 4

Rear-left: 21.8x18.0 cm, 2.10 kW - 2.5 kW

1st zone booster power: 2.5 kW

Front-left: 21.8x18.0 cm, 2.10 kW - 2.5 kW

2nd zone booster power: 2.5 kW

Rear-right: 21.8x18.0 cm, 2.10 kW - 2.5 kW

3rd zone booster power: 2.5 kW

Front-right: 21.8x18.0 cm, 2.10 kW - 2.5 kW

4th zone booster power: 2.5 kW

Power levels: 9

Left Multizone dimension: 38.5x23.0 cm

Right Multizone dimension: 38.5x23.0 cm

Bridge option: Yes

Rapid level selection

Automatic setting according to pan dimension

pan detection: Yes, min 9 cm

Automatic switch off when overheat

Automatic switch off when overflow

Protection against accidental start up

Straight edge

Control knob position: Front

Control Lock / Child Safety

Voltage (V): 220-240 V

Voltage 2 (V): 380-415 V

Frequency (Hz): 50/60 Hz

Current: 33 A

Electrical connection rating (W): 7400 W

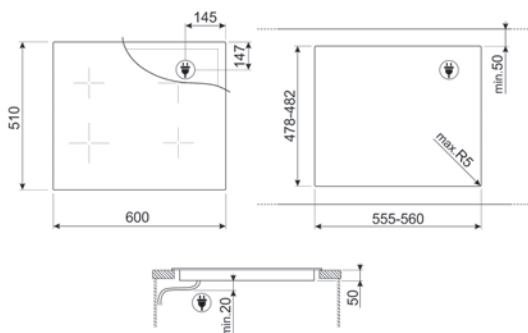

SIM3964D

INDUCTION, HOB, UNIVERSALE, 90 CM, BLACK, MULTIZONE
OPTION



PLUS:

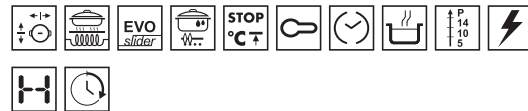

MultiZone

Built-in type: Ultra-low profile or Fully Flushed

No. of induction cook zones: 6

Front-left: 24.0x18.0 cm, 2.10 kW - 2.5 kW

1st zone booster power: 2.5 kW

Rear-left: 24.0x18.0 cm, 2.10 kW - 2.5 kW

2nd zone booster power: 2.5 kW

Front-centre: 24.0x18.0 cm, 2.10 kW - 2.5 kW

3rd zone booster power: 2.5 kW

Rear-centre: 24.0x18.0 cm, 2.10 kW - 2.5 kW

4th zone booster power: 2.5 kW

Front-right: 24.0x18.0 cm, 2.10 kW - 2.5 kW

5th zone booster power: 2.5 kW

Rear-right: 24.0x18.0 cm, 2.10 kW - 2.5 kW

6th zone booster power: 2.5 kW

Power levels: 9

Central Multizone dimension: 38.5x23.0 cm

Left Multizone dimension: 38.5x23.0 cm

Right Multizone dimension: 38.5x23.0 cm

Bridge option: Yes

Rapid level selection

Automatic setting according to pan dimension

pan detection: Yes, min 9 cm

Automatic switch off when overheat

Automatic switch off when overflow

Protection against accidental start up

Straight edge

Control knob position: Front

Control Lock / Child Safety

Voltage (V): 220-240 V

Voltage 2 (V): 380-415 V

Frequency (Hz): 50/60 Hz

Current: 49 A

Electrical connection rating (W): 11100 W

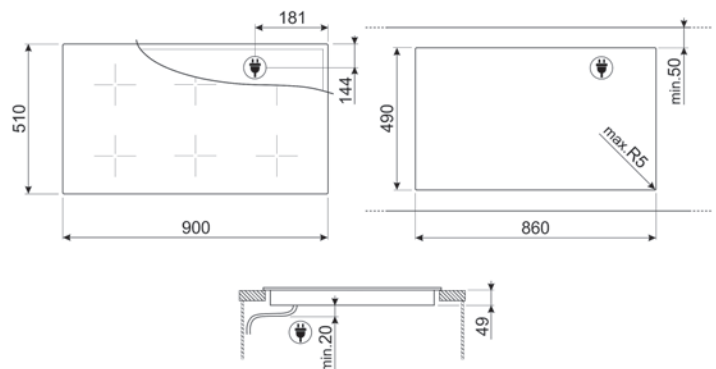

SI2M7643D

INDUCTION, HOB, UNIVERSALE, 60 CM,
BLACK, MULTIZONE OPTION



PLUS:

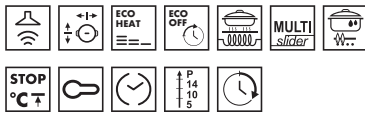

Auto-Vent
MultiZone
Built-in type: Ultra-low profile or Fully Flushed
No. of induction cook zones: 4
Front-left: Ø 21 cm, 2.30 kW - 3.20 kW
1st zone booster power: 3.20 kW
Rear-left: Ø 21 cm, 2.30 kW - 3.20 kW
2nd zone booster power: 3.20 kW
Front-right: Ø 21 cm, 2.30 kW - 3.20 kW
3rd zone booster power: 3.20 kW
Rear-right: Ø 21 cm, 2.30 kW - 3.20 kW
4th zone booster power: 3.20 kW
Power levels: 14
Left Multizone dimension: 39.2x19.5 cm
Right Multizone dimension: 39.2x19.5 cm
Rapid level selection
Automatic setting according to pan dimension
pan detection: Yes
Automatic switch off when overheat
Automatic switch off when overflow
Ceramic glass
Straight edge
Control knob position: Front
Control Lock / Child Safety

Voltage (V): 220-240 V
Voltage 2 (V): 400 V
Frequency (Hz): 50/60 Hz
Current: 32 A
Electrical connection rating (W): 7200 W

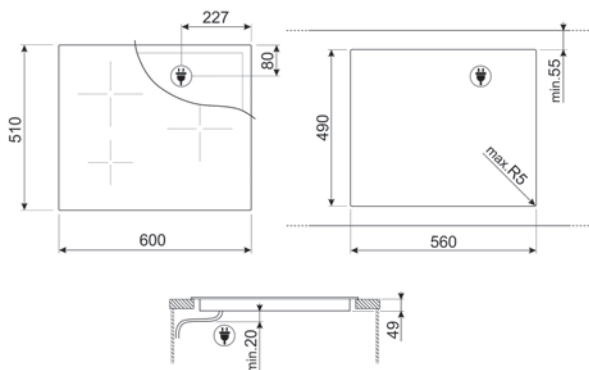

SIM3644D

INDUCTION, HOB, UNIVERSALE, 60 CM,
BLACK, MULTIZONE OPTION



PLUS:

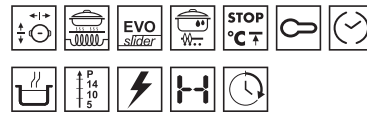

MultiZone
Built-in type: Ultra-low profile or Fully Flushed
No. of induction cook zones: 4
Rear-left: 21.8x18.0 cm, 2.10 kW - 2.5 kW
1st zone booster power: 2.5 kW
Front-left: 21.8x18.0 cm, 2.10 kW - 2.5 kW
2nd zone booster power: 2.5 kW
Rear-right: 21.8x18.0 cm, 2.10 kW - 2.5 kW
3rd zone booster power: 2.5 kW
Front-right: 21.8x18.0 cm, 2.10 kW - 2.5 kW
4th zone booster power: 2.5 kW
Power levels: 9
Left Multizone dimension: 38.5x23.0 cm
Right Multizone dimension: 38.5x23.0 cm
Bridge option: Yes
Rapid level selection
Automatic setting according to pan dimension
pan detection: Yes, min 9 cm
Automatic switch off when overheat
Automatic switch off when overflow
Protection against accidental start up
Straight edge
Control knob position: Front
Control Lock / Child Safety

Voltage (V): 220-240 V
Voltage 2 (V): 380-415 V
Frequency (Hz): 50/60 Hz
Current: 33 A
Electrical connection rating (W): 7400 W

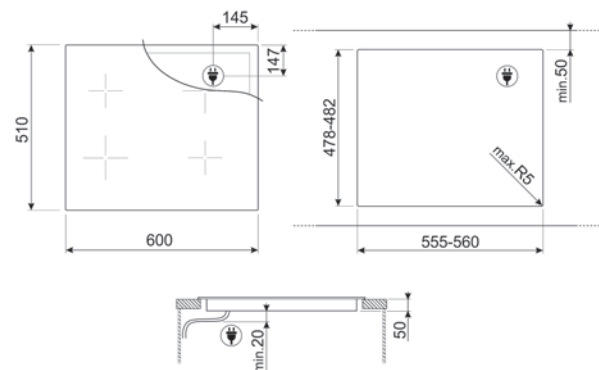

SIM3323D

INDUCTION, HOB, UNIVERSALE,
38 CM, BLACK, MULTIZONE
OPTION



PLUS:

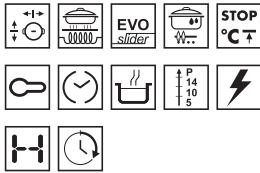

MultiZone

Built-in type: Ultra-low profile or Fully Flushed

No. of induction cook zones: 2
Front-centre: 24.0x18.0 cm,
2.10 kW - 2.5 kW

1st zone booster power: 2.5 kW
Rear-centre: 24.0x18.0 cm,
2.10 kW - 2.5 kW

2nd zone booster power:
2.5 kW

Power levels: 9

Central Multizone dimension:
38.5x23.0 cm

Bridge option: Yes

Rapid level selection

Automatic setting according to
pan dimension

pan detection: Yes, min 9 cm
Automatic switch off when
overheat

Automatic switch off when
overflow

Protection against accidental
start up

Straight edge

Control knob position: Front
Control Lock / Child Safety

Voltage (V): 220-240 V

Frequency (Hz): 50/60 Hz

Current: 16 A

Electrical connection rating (W):
3700 W

SI5322B

INDUCTION, HOB, UNIVERSALE,
30 CM, BLACK



PLUS:

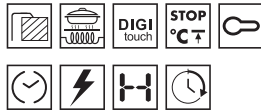

Built-in type: Ultra-low profile

No. of induction cook zones: 2

Front-centre: Ø 16.0 cm,
1.30 kW - 1.40 kW

1st zone booster power:
1.40 kW

Rear-centre: Ø 21.0 cm,
2.30 kW - 3.00 kW

2nd zone booster power:
3.00 kW

Power levels: 9

Automatic setting according to

pan dimension

pan detection: Yes

Automatic switch off when
overheat

Protection against accidental
start up

Ceramic glass

Angled edge

Control knob position: Front

Control Lock / Child Safety

Voltage (V): 220-240 V

Frequency (Hz): 50/60 Hz

Current: 16 A

Electrical connection rating (W):
3500 W

PV331CN

GAS, HOB, CLASSICA, 30 CM,
BLACK, WHITE



PLUS:



Built-in type: Ultra-low profile or Fully Flushed

Central: 6.00 kW

Cast iron

Gas safety valves

Ceramic glass

Straight edge

Control knob position: Front

Smeg Contemporary

Burners Material: Brass

Burner Coating: Nichelato

Controls colour: Steel effect

Voltage (V): 220-240 V

Frequency (Hz): 50/60 Hz

Electrical connection rating (W):
1 W

PV332CN

GAS, HOB, CLASSICA, 30 CM,
BLACK



PLUS:



Built-in type: Ultra-low profile or Fully Flushed

Front-centre: 1.80 kW

Rear-centre: 3.00 kW

Cast iron

Gas safety valves

Ceramic glass

Straight edge

Control knob position: Front

Smeg Contemporary

Burners Material: Brass

Burner Coating: Nichelato

Controls colour: Steel effect

Voltage (V): 220-240 V

Frequency (Hz): 50/60 Hz

Electrical connection rating (W):
1 W

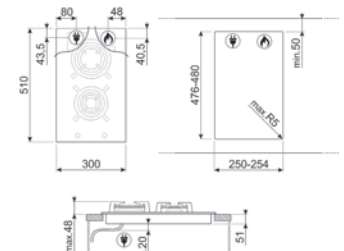
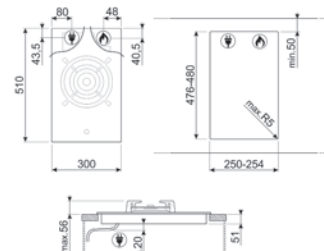
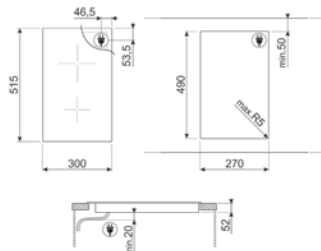
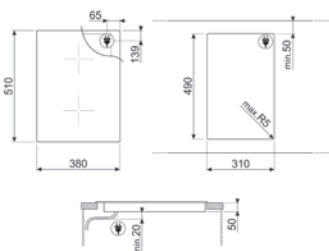

PGF31G-1

GAS, HOB, CLASSICA, 30 CM,
STAINLESS STEEL



PLUS:



Built-in type: Ultra-low profile
Central: 5.20 kW
Cast iron
Gas safety valves
Control knob position: Front
Standard
Burners Material: Alluminium
Controls colour: Steel effect

Voltage (V): 220-240 V
Frequency (Hz): 50/60 Hz
Electrical connection rating (W):
1 W

PGF32G

GAS, HOB, CLASSICA, 30 CM,
STAINLESS STEEL



PLUS:



Built-in type: Ultra-low profile
Front-centre: 1.05 kW
Rear-centre: 2.50 kW
Cast iron
Gas safety valves
Control knob position: Front
Controls colour: Steel effect

Voltage (V): 220-240 V
Frequency (Hz): 50/60 Hz
Electrical connection rating (W):
1 W

ACCESSORIES INCLUDED:
Other accessories: Linea control
knobs kit

PGF32I-1

INDUCTION, HOB, CLASSICA,
30 CM, STAINLESS STEEL



PLUS:



Built-in type: Ultra-low profile
No. of induction cook zones: 2
Front-centre: Ø 14.5 cm,
1.40 kW - 2.20 kW
1st zone booster power:
2.20 kW
Rear-centre: Ø 21.0 cm,
1.80 kW - 3.00 kW
2nd zone booster power:
3.00 kW
Automatic setting according to
pan dimension
pan detection: Yes
Automatic switch off when
overheat
Protection against accidental
start up
Control knob position: Front
Controls colour: Steel effect
Control Lock / Child Safety

Voltage (V): 220-240 V
Frequency (Hz): 50/60 Hz
Current: 16 A
Electrical connection rating (W):
3500 W

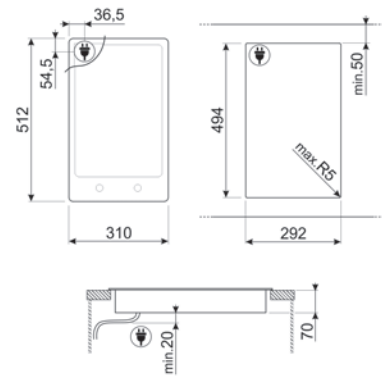
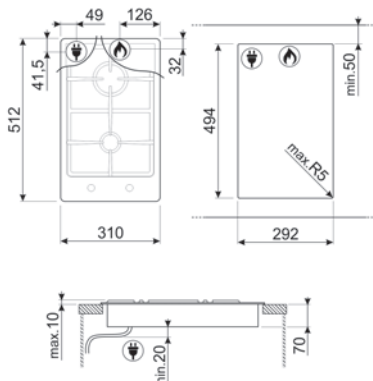
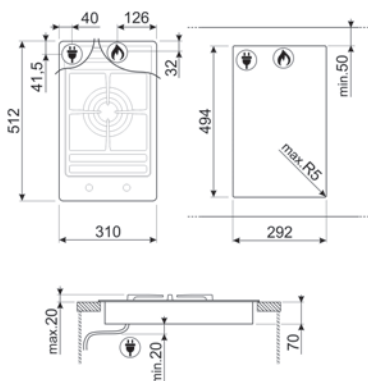

PGF30B

HOB, CLASSICA, 30 CM,
STAINLESS STEEL



PLUS:



Built-in type: Ultra-low profile
No. of electric plate cook zones: 1
Power levels: 9
Cast iron
Control knob position: Front
Controls colour: Steel effect

Voltage (V): 220-240 V
Frequency (Hz): 50/60 Hz
Current: 8 A
Electrical connection rating (W): 1800 W

ACCESSORIES INCLUDED:
Other accessories: Linea control knobs kit

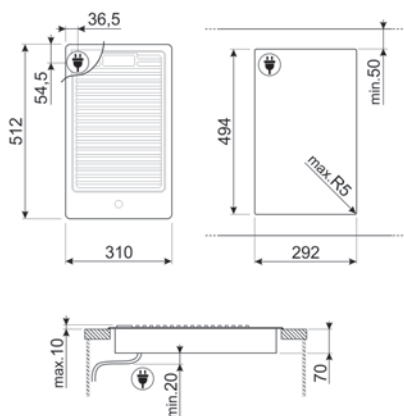

PGF30T-1

TEPPANYAKI, HOB, CLASSICA,
30 CM, STAINLESS STEEL



PLUS:



Built-in type: Ultra-low profile
No. of induction cook zones: 2
Front-centre: 1.40 kW - 1.80 kW
1st zone booster power: 1.80 kW
Rear-centre: 1.40 kW - 1.80 kW
2nd zone booster power: 1.80 kW
Power levels: 9
Automatic switch off when overheat
Control knob position: Front
Controls colour: Steel effect
Control Lock / Child Safety

Voltage (V): 220-240 V
Frequency (Hz): 50/60 Hz
Current: 13 A
Electrical connection rating (W): 3000 W

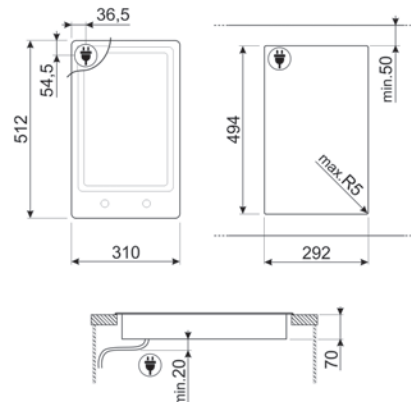



KDD90CNE

KDD90CNE2

DOWNDRAFT, UNIVERSALE, 90 CM, BLACK



PLUS:



No. of speeds	I	II	III	IV	INT
Extraction rate IEC 61591 m³/h	160	290	350	430	700
Noise level IEC 60704-2- 13 dB(A)	40	53	54	60	70

- Motor power: 270 W
- Free outlet maximum capacity: 725 m³/h
- Remote motor
- Black
- Electronic control
- Touch control
- No. of speeds: 4
- Intensive speed
- Time-setting options
- 2 aluminium grease filters
- Vent outlet: 150 mm
- Fluid Dynamic Efficiency class (FDEC): A
- Lighting Efficiency Class (LEC): A
- Grease Filtering Efficiency Class (GFEC): D
- Sound power level at highest setting (Lwa): 54 dB(A)

Frequency (Hz): 50-60 Hz
Voltage: 220-240 V

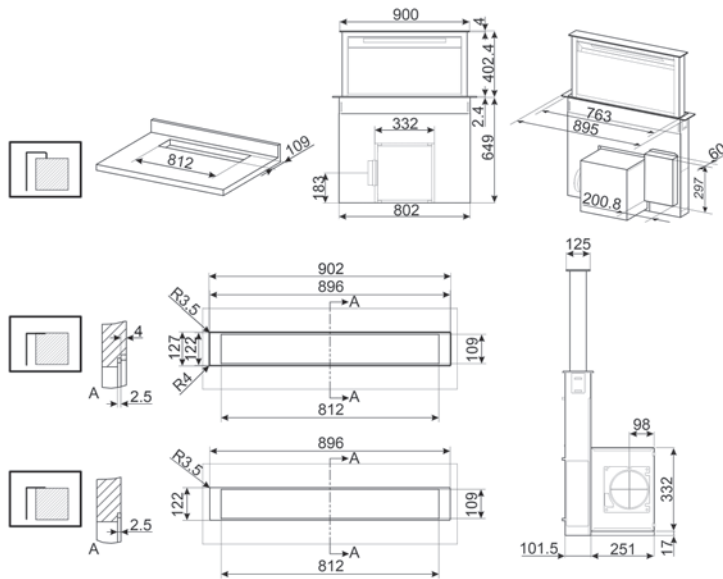

KSCB124X

CEILING HOOD, UNIVERSALE, 120 CM, STAINLESS STEEL



PLUS:



No. of speeds	I	II	III	INT
Extraction rate IEC 61591 m ³ /h	293	420	655	808
Noise level IEC 60704-2-13 dB(A)	51	58	67	71

Motor power: 275 W
 Free outlet maximum capacity: 820 m³/h
 Electronic control
 Electronic buttons
 No. of speeds: 3
 Intensive speed
 2 st/steel grease filters
 Vent outlet: 150 mm
 Non return valve
 4 led lamps (1 W)
 Fluid Dynamic Efficiency class (FDEC): A
 Lighting Efficiency Class (LEC): A
 Grease Filtering Efficiency Class (GFEC): F
 Sound power level at highest setting (Lwa): 66 dB(A)

Frequency (Hz): 50-60 Hz
 Voltage: 220-240 V

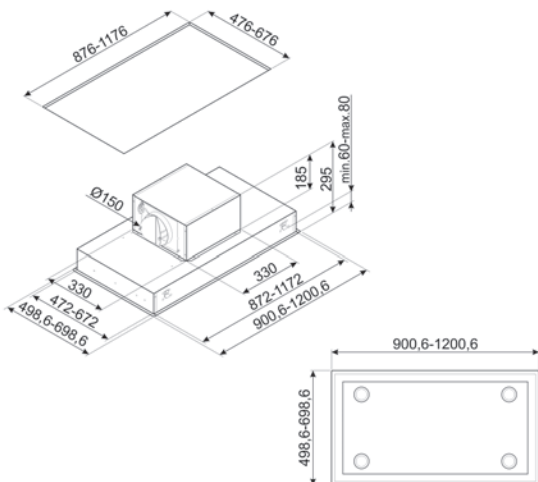

KSCB94X

CEILING HOOD, UNIVERSALE, 90 CM, STAINLESS STEEL



PLUS:



No. of speeds	I	II	III	INT
Extraction rate IEC 61591 m ³ /h	232	428	589	792
Noise level IEC 60704-2-13 dB(A)	47	58	69	72

Motor power: 275 W
 Free outlet maximum capacity: 820 m³/h
 Electronic control
 Electronic buttons
 No. of speeds: 3
 Intensive speed
 2 st/steel grease filters
 Vent outlet: 150 mm
 Non return valve
 4 led lamps (1 W)
 Fluid Dynamic Efficiency class (FDEC): A
 Lighting Efficiency Class (LEC): A
 Grease Filtering Efficiency Class (GFEC): F
 Sound power level at highest setting (Lwa): 68 dB(A)

Frequency (Hz): 50-60 Hz
 Voltage: 220-240 V

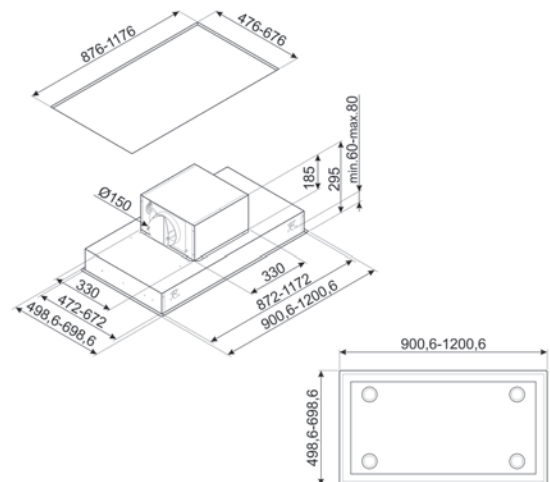

KI120XE

DECORATIVE ISLAND HOOD, UNIVERSALE, 120 CM, STAINLESS STEEL



PLUS:



No. of speeds	I	II	III	INT
Extraction rate IEC 61591 m ³ /h	316	385	529	783
Noise level IEC 60704-2-13 dB(A)	48	59	62	70

Motor power: 275 W
 Free outlet maximum capacity: 820 m³/h
 Electronic control
 Electronic buttons
 No. of speeds: 3
 Intensive speed
 Time-setting options
 4 aluminium grease filters
 Vent outlet: 150 mm
 Non return valve
 4 led lamps (1 W)
 Fluid Dynamic Efficiency class (FDEC): A
 Lighting Efficiency Class (LEC): A
 Grease Filtering Efficiency Class (GFEC): C
 Sound power level at highest setting (Lwa): 62 dB(A)

Frequency (Hz): 50-60 Hz
 Voltage: 220-240 V

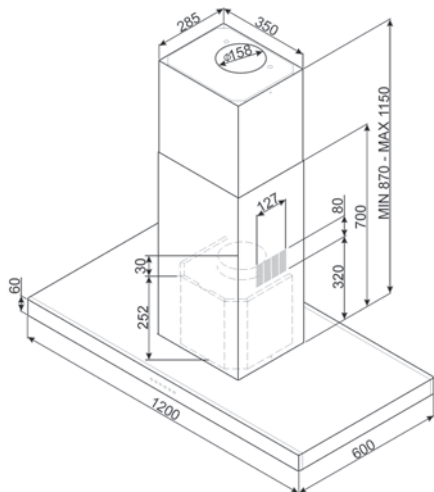

KI90XE

DECORATIVE ISLAND HOOD, UNIVERSALE, 90 CM, STAINLESS STEEL



PLUS:



No. of speeds	I	II	III	INT
Extraction rate IEC 61591 m ³ /h	311	385	533	740
Noise level IEC 60704-2-13 dB(A)	49	59	63	71

Motor power: 275 W
 Free outlet maximum capacity: 820 m³/h
 Electronic control
 Electronic buttons
 No. of speeds: 3
 Intensive speed
 Time-setting options
 3 aluminium grease filters
 Vent outlet: 150 mm
 Non return valve
 4 led lamps (1 W)
 Fluid Dynamic Efficiency class (FDEC): B
 Lighting Efficiency Class (LEC): A
 Grease Filtering Efficiency Class (GFEC): C
 Sound power level at highest setting (Lwa): 63 dB(A)

Frequency (Hz): 50-60 Hz
 Voltage: 220-240 V

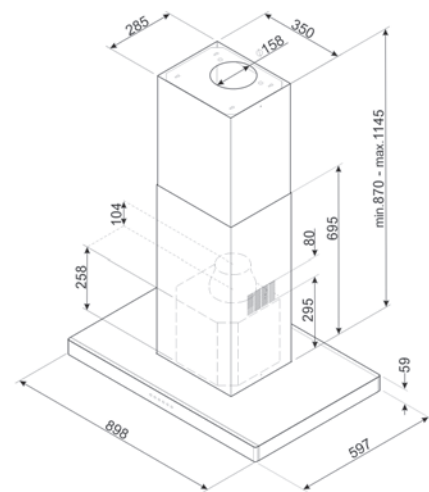



KV194B3

DECORATIVE WALL HOOD, LINEA, 90 CM, BLACK



PLUS:



No. of speeds	I	II	III	INT
Extraction rate IEC 61591 m ³ /h	277	406	636	782
Noise level IEC 60704-2-13 dB(A)	50	63	70	72

Motor power: 275 W
 Free outlet maximum capacity: 820 m³/h
 Black
 Electronic control
 Touch control back-lighted White
 No. of speeds: 3
 Intensive speed
 Time-setting options
 2 st/steel grease filters
 Vent outlet: 150 mm
 Non return valve
 Fluid Dynamic Efficiency class (FDEC): A
 Lighting Efficiency Class (LEC): A
 Grease Filtering Efficiency Class (GFEC): E
 Sound power level at highest setting (Lwa): 71 dB(A)

Frequency (Hz): 50-60 Hz
 Voltage: 220-240 V

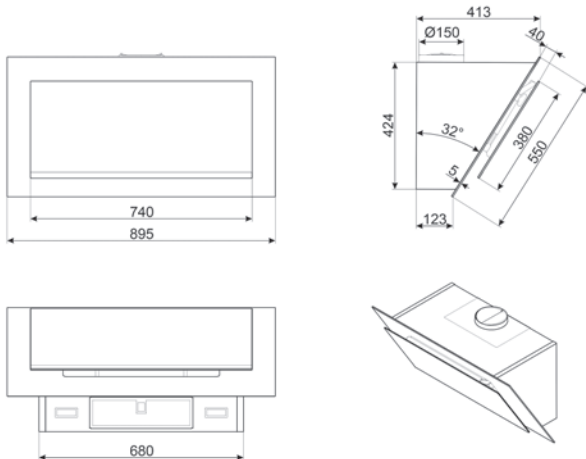

KV394N

DECORATIVE WALL HOOD, UNIVERSALE, 90 CM, BLACK



PLUS:



No. of speeds	I	II	III	INT
Extraction rate IEC 61591 m ³ /i h	285	374	493	729
Noise level IEC 60704-2-13 dB(A)	47	54	60	69

Motor power: 230 W
 Free outlet maximum capacity: 730 m³/h
 Black
 Electronic control
 Touch control back-lighted White
 No. of speeds: 3
 Intensive speed
 Time-setting options
 2 aluminium grease filters
 Vent outlet: 150 mm
 Non return valve
 Fluid Dynamic Efficiency class (FDEC): A
 Lighting Efficiency Class (LEC): A
 Grease Filtering Efficiency Class (GFEC): D
 Sound power level at highest setting (Lwa): 61 dB(A)

Frequency (Hz): 50-60 Hz
 Voltage: 220-240 V

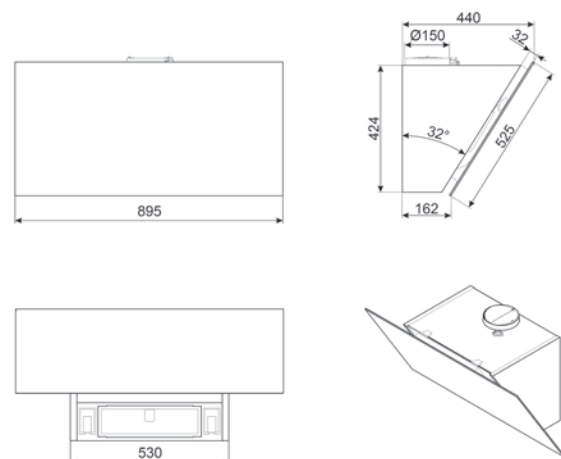



KICV90BL2

DECORATIVE WALL HOOD, UNIVERSALE, 90 CM, BLACK



PLUS:



No. of speeds	I	II	III	INT
Extraction rate IEC 61591 m ³ /h	310	420	580	720
Noise level IEC 60704-2- 13 dB(A)	52	56	62	65

Motor power: 270 W
 Free outlet maximum capacity: 750 m³/h
 Black
 Electronic control
 Touch control
 No. of speeds: 3
 Intensive speed
 Time-setting options
 2 aluminium grease filters
 Vent outlet: 150 mm
 2 led lamps (1 W)
 Fluid Dynamic Efficiency class (FDEC): A
 Lighting Efficiency Class (LEC): A
 Grease Filtering Efficiency Class (GFEC): F
 Sound power level at highest setting (Lwa): 62 dB(A)

Frequency (Hz): 50-60 Hz
 Voltage: 220-240 V

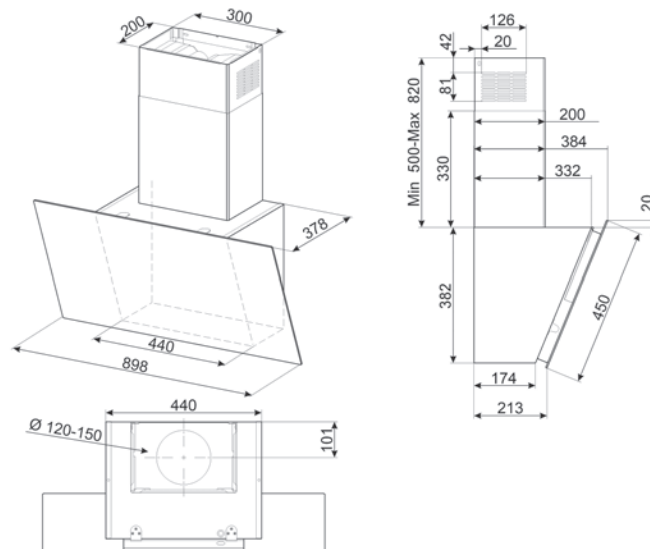

KD150HXE

DECORATIVE WALL HOOD, CLASSICA, 150 CM, STAINLESS STEEL



PLUS:



No. of speeds	I	II	III	INT
Extraction rate IEC 61591 m ³ /h	292	415	626	787
Noise level IEC 60704-2- 13 dB(A)	49	58	67	72

Motor power: 275 W
 Free outlet maximum capacity: 830 m³/h
 Control knobs: Classic
 Control knobs
 No. of speeds: 3
 Intensive speed
 5 st/steel grease filters
 Vent outlet: 150 mm
 Non return valve
 4 led lamps (1 W)
 Fluid Dynamic Efficiency class (FDEC): A
 Lighting Efficiency Class (LEC): A
 Grease Filtering Efficiency Class (GFEC): D
 Sound power level at highest setting (Lwa): 68 dB(A)

Frequency (Hz): 50-60 Hz
 Voltage: 220-240 V

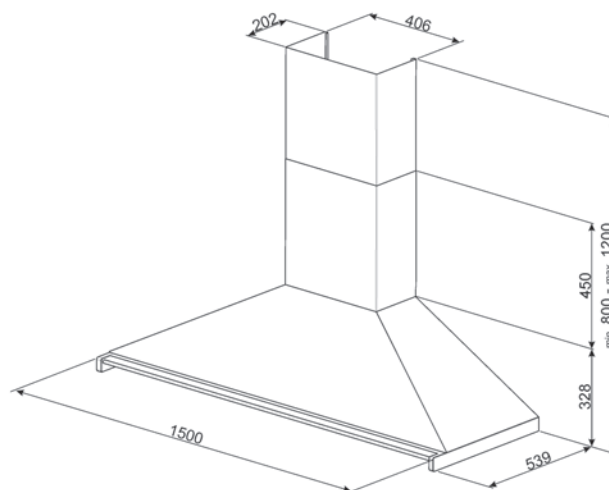

KD120HXE

DECORATIVE WALL HOOD, CLASSICA, 120 CM, STAINLESS STEEL



PLUS:



No. of speeds	I	II	III	INT
Extraction rate IEC 61591 m ³ /h	287	389	606	777
Noise level IEC 60704-2-13 dB(A)	49	58	67	73

Motor power: 275 W
 Free outlet maximum capacity: 820 m³/h
 Control knobs: Classic
 Control knobs
 No. of speeds: 3
 Intensive speed
 4 st/steel grease filters
 Vent outlet: 150 mm
 Non return valve
 Fluid Dynamic Efficiency class (FDEC): A
 Lighting Efficiency Class (LEC): A
 Grease Filtering Efficiency Class (GFEC): D
 Sound power level at highest setting (Lwa): 67 dB(A)

Frequency (Hz): 50-60 Hz
 Voltage: 220-240 V

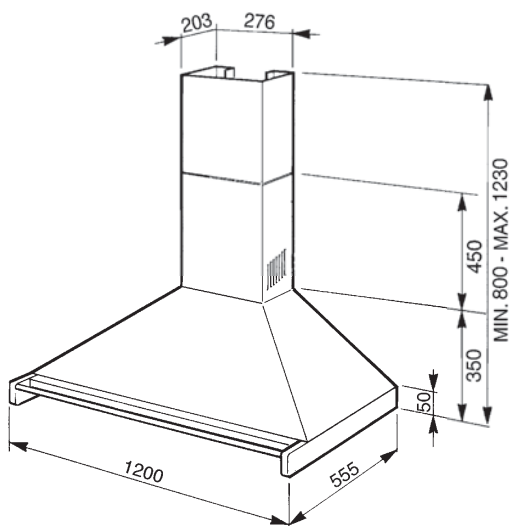

KD90HXE

DECORATIVE WALL HOOD, CLASSICA, 90 CM, STAINLESS STEEL



PLUS:



No. of speeds	I	II	III	INT
Extraction rate IEC 61591 m ³ /h	288	421	630	781
Noise level IEC 60704-2-13 dB(A)	48	63	67	72

Motor power: 275 W
 Free outlet maximum capacity: 815 m³/h
 Control knobs: Classic
 Control knobs
 No. of speeds: 3
 Intensive speed
 3 st/steel grease filters
 Vent outlet: 150 mm
 Non return valve
 2 led lamps (1 W)
 Fluid Dynamic Efficiency class (FDEC): A
 Lighting Efficiency Class (LEC): A
 Grease Filtering Efficiency Class (GFEC): C
 Sound power level at highest setting (Lwa): 67 dB(A)

Frequency (Hz): 50-60 Hz
 Voltage: 220-240 V

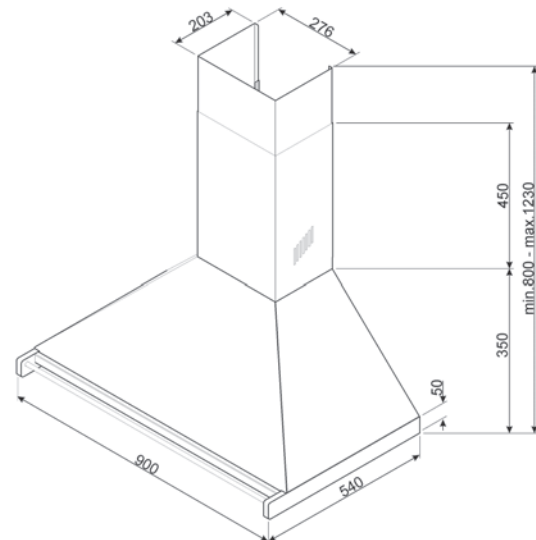

KPF12BL

DECORATIVE WALL HOOD, PORTOFINO, 120 CM, BLACK



KPF12RD

DECORATIVE WALL HOOD, PORTOFINO, 120 CM, RED



PLUS:



No. of speeds	I	II	III	INT
Extraction rate IEC 61591 m ³ /h	287	389	606	777
Noise level IEC 60704-2- 13 dB(A)	49	58	67	73

Motor power: 275 W
 Free outlet maximum capacity: 815 m³/h
 Control knobs: Portofino
 Control knobs
 No. of speeds: 3
 Intensive speed
 4 st/steel grease filters
 Vent outlet: 150 mm
 Non return valve
 Fluid Dynamic Efficiency class (FDEC): A
 Lighting Efficiency Class (LEC): A
 Grease Filtering Efficiency Class (GFEC): D
 Sound power level at highest setting (Lwa): 67 dB(A)

Frequency (Hz): 50-60 Hz
 Voltage: 220-240 V

KPF12T

DECORATIVE WALL HOOD, PORTOFINO, 120 CM, TURQUESE

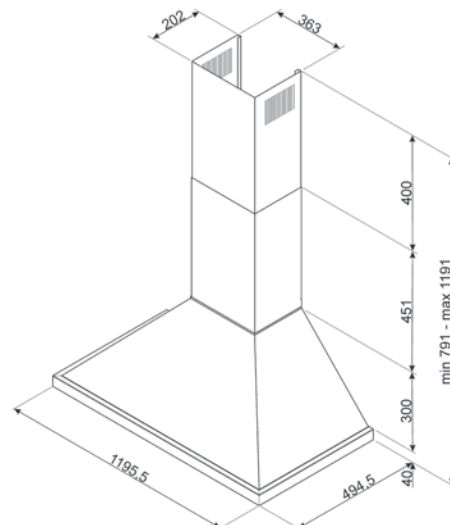

KPF12BL - KPF12RD - KPF12T

KPF12WH

DECORATIVE WALL HOOD, PORTOFINO, 120 CM, WHITE



KPF12X

DECORATIVE WALL HOOD, PORTOFINO, 120 CM, STAINLESS STEEL



PLUS:



No. of speeds	I	II	III	INT
Extraction rate IEC 61591 m ³ /h	287	389	606	777
Noise level IEC 60704-2- 13 dB(A)	49	58	67	73

Motor power: 275 W
 Free outlet maximum capacity: 815 m³/h
 Control knobs: Portofino
 Control knobs
 No. of speeds: 3
 Intensive speed
 4 st/steel grease filters
 Vent outlet: 150 mm
 Non return valve
 Fluid Dynamic Efficiency class (FDEC): A
 Lighting Efficiency Class (LEC): A
 Grease Filtering Efficiency Class (GFEC): D
 Sound power level at highest setting (Lwa): 67 dB(A)

Frequency (Hz): 50-60 Hz
 Voltage: 220-240 V

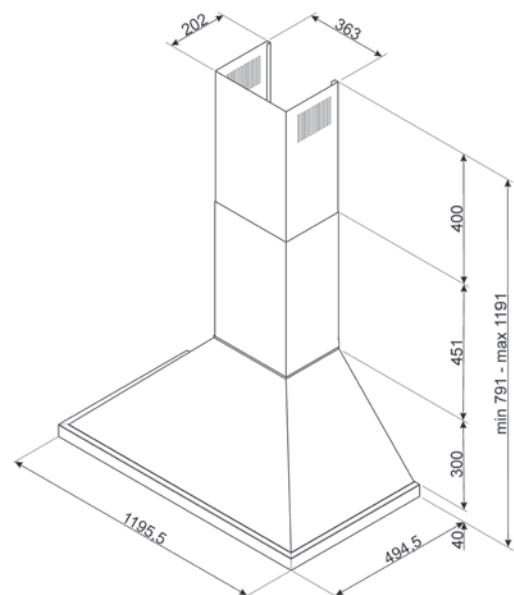

KPF12WH - KPF12X

KPF9AN

DECORATIVE WALL HOOD, PORTOFINO, 90 CM, ANTHRACITE



KPF9BL

DECORATIVE WALL HOOD, PORTOFINO, 90 CM, BLACK



PLUS:



No. of speeds	I	II	III	INT
Extraction rate IEC 61591 m ³ /h	288	421	630	781
Noise level IEC 60704-2- 13 dB(A)	48	63	67	72

Motor power: 275 W
 Free outlet maximum capacity: 815 m³/h
 Control knobs: Portofino
 Control knobs
 No. of speeds: 3
 Intensive speed
 3 st/steel grease filters
 Vent outlet: 150 mm
 Non return valve
 2 led lamps (2 W)
 Fluid Dynamic Efficiency class (FDEC): A
 Lighting Efficiency Class (LEC): A
 Grease Filtering Efficiency Class (GFEC): C
 Sound power level at highest setting (Lwa): 67 dB(A)

Frequency (Hz): 50-60 Hz
 Voltage: 220-240 V

KPF9OG

DECORATIVE WALL HOOD, PORTOFINO, 90 CM, OLIVE GREEN



KPF9OR

DECORATIVE WALL HOOD, PORTOFINO, 90 CM, ORANGE

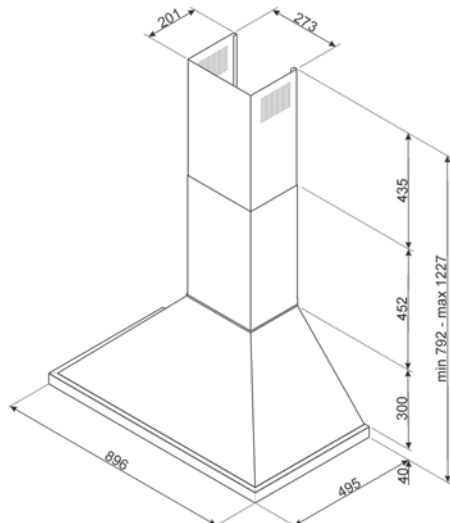

KPF9AN - KPF9BL - KPF9OG - KPF9OR

KPF9RD

DECORATIVE WALL HOOD, PORTOFINO, 90 CM, RED



PLUS:

A+

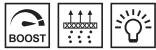

No. of speeds	I	II	III	INT
Extraction rate IEC 61591 m ³ /h	288	421	630	781
Noise level IEC 60704-2- 13 dB(A)	48	63	67	72

Motor power: 275 W
 Free outlet maximum capacity: 815 m³/h
 Control knobs: Portofino
 Control knobs
 No. of speeds: 3
 Intensive speed
 3 st/steel grease filters
 Vent outlet: 150 mm
 Non return valve
 2 led lamps (2 W)
 Fluid Dynamic Efficiency class (FDEC): A
 Lighting Efficiency Class (LEC): A
 Grease Filtering Efficiency Class (GFEC): C
 Sound power level at highest setting (Lwa): 67 dB(A)

Frequency (Hz): 50-60 Hz
 Voltage: 220-240 V

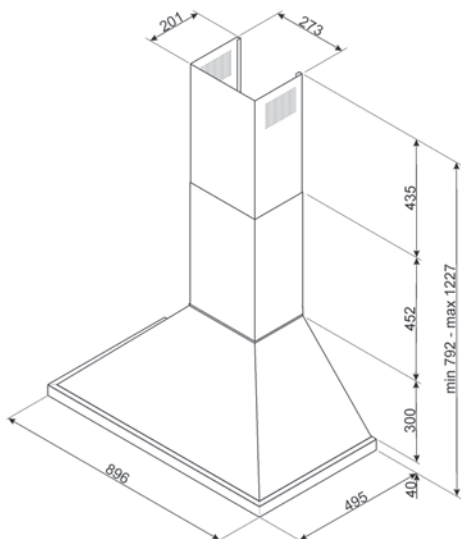

KPF9RD - KPF9WH - KPF9X - KPF9YW

KPF9WH

DECORATIVE WALL HOOD, PORTOFINO, 90 CM, WHITE



KPF9X

DECORATIVE WALL HOOD, PORTOFINO, 90 CM, STAINLESS STEEL



KPF9YW

DECORATIVE WALL HOOD, PORTOFINO, 90 CM, YELLOW



KBT1200XE

DECORATIVE WALL HOOD, UNIVERSALE, 120 CM, STAINLESS STEEL



PLUS:



No. of speeds	I	II	III	INT
Extraction rate IEC 61591 m ³ /h	251	345	454	690
Noise level IEC 60704-2- 13 dB(A)	48	56	62	72

Motor power: 230 W
 Free outlet maximum capacity: 610 m³/h
 Electronic control
 Electronic buttons
 No. of speeds: 3
 Intensive speed
 Time-setting options
 4 aluminium grease filters
 Vent outlet: 150 mm
 Non return valve
 Fluid Dynamic Efficiency class (FDEC): A
 Lighting Efficiency Class (LEC): A
 Grease Filtering Efficiency Class (GFEC): C
 Sound power level at highest setting (Lwa): 72 dB(A)

Frequency (Hz): 50-60 Hz
 Voltage: 220-240 V

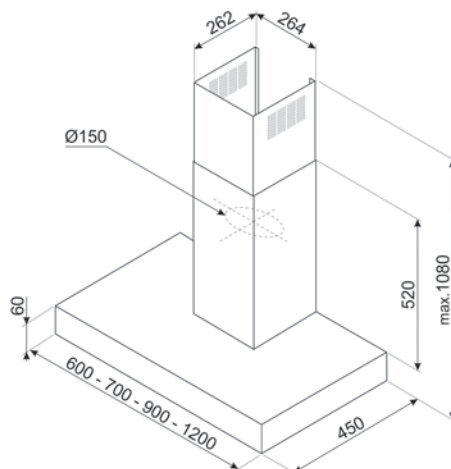

KBT900XE

DECORATIVE WALL HOOD, UNIVERSALE, 90 CM, STAINLESS STEEL



PLUS:



No. of speeds	I	II	III	INT
Extraction rate IEC 61591 m ³ /h	265	360	480	713
Noise level IEC 60704-2-13 dB(A)	47	55	62	72

Motor power: 230 W
 Free outlet maximum capacity: 730 m³/h
 Electronic control
 Electronic buttons
 No. of speeds: 3
 Intensive speed
 Time-setting options
 3 aluminium grease filters
 Vent outlet: 150 mm
 Non return valve
 Fluid Dynamic Efficiency class (FDEC): A
 Lighting Efficiency Class (LEC): A
 Grease Filtering Efficiency Class (GFEC): C
 Sound power level at highest setting (Lwa): 62 dB(A)

Frequency (Hz): 50-60 Hz
 Voltage: 220-240 V

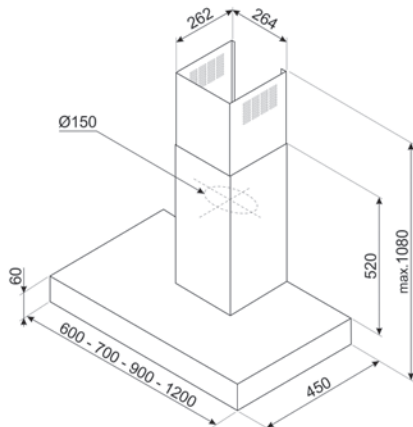

KBT600XE

DECORATIVE WALL HOOD, UNIVERSALE, 60 CM, STAINLESS STEEL



PLUS:



No. of speeds	I	II	III	INT
Extraction rate IEC 61591 m ³ /h	260	358	473	686
Noise level IEC 60704-2-13 dB(A)	49	57	64	72

Motor power: 230 W
 Free outlet maximum capacity: 820 m³/h
 Electronic control
 Electronic buttons
 No. of speeds: 3
 Intensive speed
 Time-setting options
 2 aluminium grease filters
 Vent outlet: 150 mm
 Non return valve
 Fluid Dynamic Efficiency class (FDEC): A
 Lighting Efficiency Class (LEC): A
 Grease Filtering Efficiency Class (GFEC): C
 Sound power level at highest setting (Lwa): 70 dB(A)

Frequency (Hz): 50-60 Hz
 Voltage: 220-240 V

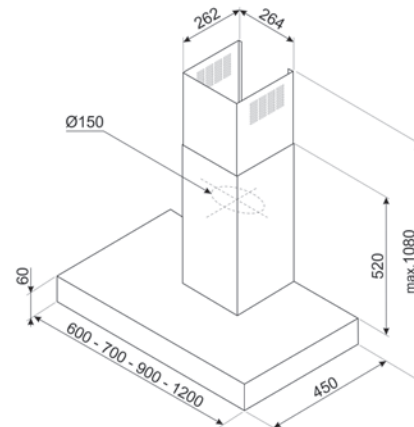



KSET900XE

INTEGRATED (SEMI) HOOD, UNIVERSALE, 90 CM, STAINLESS STEEL



PLUS:



No. of speeds	I	II	III
Extraction rate IEC 61591 m ³ /h	240	368	581
Noise level IEC 60704-2-13 dB(A)	44	54	65

Motor power: 175 W
 Free outlet maximum capacity: 600 m³/h
 Slider
 No. of speeds: 3
 2 aluminium grease filters
 Vent outlet: 150 mm
 Non return valve
 Fluid Dynamic Efficiency class (FDEC): C
 Lighting Efficiency Class (LEC): A
 Grease Filtering Efficiency Class (GFEC): C
 Sound power level at highest setting (Lwa): 65 dB(A)

Frequency (Hz): 50-60 Hz
 Voltage: 220-240 V

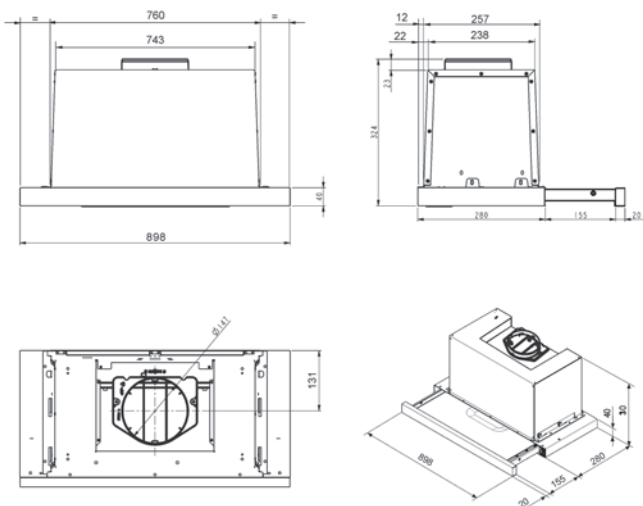

KSET600XE

INTEGRATED (SEMI) HOOD, UNIVERSALE, 60 CM, STAINLESS STEEL



PLUS:



No. of speeds	I	II	III
Extraction rate IEC 61591 m ³ /h	240	368	581
Noise level IEC 60704-2-13 dB(A)	44	54	65

Motor power: 175 W
 Free outlet maximum capacity: 603 m³/h
 Slider
 No. of speeds: 3
 2 aluminium grease filters
 Vent outlet: 150 mm
 Non return valve
 Fluid Dynamic Efficiency class (FDEC): C
 Lighting Efficiency Class (LEC): A
 Grease Filtering Efficiency Class (GFEC): C
 Sound power level at highest setting (Lwa): 65 dB(A)

Frequency (Hz): 50-60 Hz
 Voltage: 220-240 V

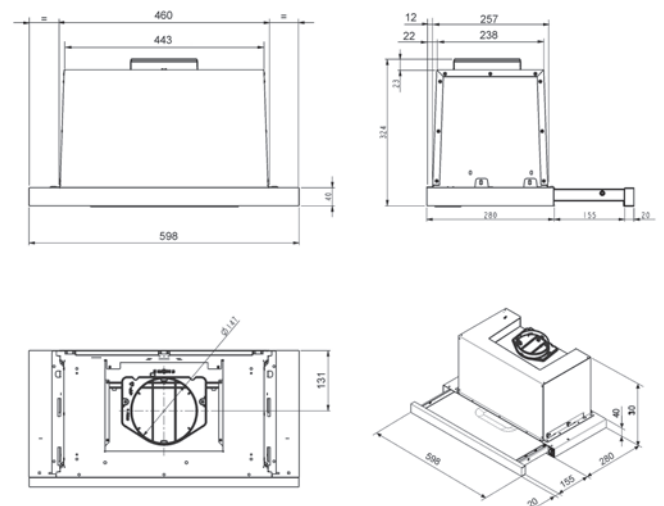



SO6303APX

SFP9302TX

THERMO-VENTILATED OVEN, PYROLITIC, CLASSICA, 90CM, STAINLESS STEEL



PLUS:



FUNCTIONS:



Gross volume: 129 l
 Net volume of the cavity: 115 l
 Automatic programmes: 50
 Customisable recipes: 10
 Display technology: TFT
 Delay start and automatic end cooking
 Door opening type: Standard opening
 Minute minder: Yes
 Timer: Electronic
 End of cooking acoustic alarm
 Temperature control: Electronic
 Heating suspended when door is opened
 Door Lock During Pyrolysis
 Temperatures: from 30°C to 280°C
 Soft Close hinges
 Eclipse
 Light when door is opened
 2 halogen lamps (40 W)

Nominal power: 4000 W
 Limited Power Consumption Mode
 Energy consumption per cycle in conventional mode: 0.84 KWh
 Energy consumption in conventional mode: 3.02 Mj
 Energy consumption per cycle in fan-forced convection: 1.45 KWh
 Energy consumption in forced air convection: 5.22 Mj

Frequency (Hz): 50/60 Hz
 Current: 18 A
 Voltage: 220-240 V

ACCESSORIES INCLUDED:

Enamelled deep tray (40mm): 2
 Insert grid: 1
 Rack with back and side stop: 1
 Telescopic Guide rails, total Extraction: 1

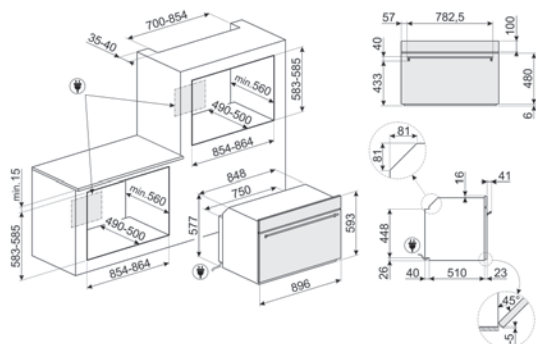

SO6302TX

THERMO-VENTILATED OVEN, VAPOR CLEAN, CLASSICA, 60CM, STAINLESS STEEL



PLUS:

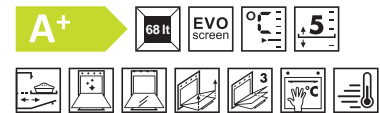

FUNCTIONS:



Gross volume: 78 l
 Net volume of the cavity: 68 l
 Display: 02
 Display technology: LCD
 Delay start and automatic end cooking
 Door opening type: Standard opening
 Minute minder: Yes
 Timer: Electronic
 End of cooking acoustic alarm
 Temperature control: Electronic
 Heating suspended when door is opened
 Temperatures: from 30°C to 280°C
 Soft Close hinges
 Eclipse
 Light when door is opened
 2 halogen lamps (40 W)

Nominal power: 3000 W
 Energy consumption per cycle in conventional mode: 1.15 KWh
 Energy consumption in conventional mode: 4.14 Mj
 Energy consumption per cycle in fan-forced convection: 0.68 KWh
 Energy consumption in forced air convection: 2.45 Mj

Frequency (Hz): 50/60 Hz
 Current: 13 A
 Voltage: 220-240 V

ACCESSORIES INCLUDED:

Enamelled tray (20mm): 1
 Insert grid: 1
 Rack with back stop: 1
 Telescopic Guide rails, partial Extraction: 1

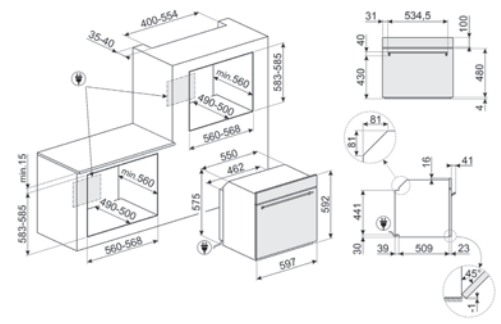

SO6302TX

FMI325X

MICROWAVE, BUILT-IN, CLASSICA,
STAINLESS STEEL



PLUS:

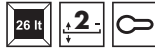

Microwave with grill
Automatic programmes: 8
Gross volume: 26 l
Net volume: 25 l
Stainless steel
1 x LED
End of cooking acoustic alarm
Eclipse
Door: Full glass
End cooking
Quick start option
Light when door is opened
Turntable dimensions: 31.5 cm
Grid: 1
Shelves type: Rack
Frame
Microwave stops when door is opened
Microwave screen protection
Microwave effective power: 900 W
Quartz Grill: 1 Kw
Safety Thermostat
Touch control

Frequency (Hz): 50 Hz
Current: 6.3 A
Voltage (V): 230 V

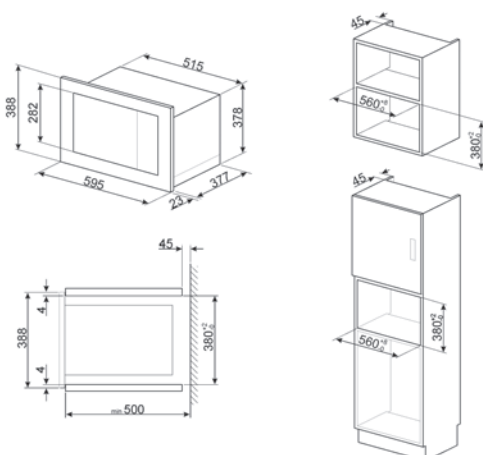





S8F174DNE + S8L174D3E

S9F174ND

FREEZERS, SINGLE DOOR, BUILT-IN NICHE:
178



PLUS:



Net freezing capacity: 204 l
Fast freezing button
Temperature alarm
Number of drawers: 5
No. of compartments with flap: 2
Door on door

Freezing capacity: 20 Kg/24h
Temperature Rise Time: 24 h
Climatic class: SN, N, ST, T
Annual energy consumption: 238 kWh
Electrical connection rating: 140 W

Frequency (Hz): 50 Hz
Voltage: 230-240 V
Current: 1 A

Reversible door with right hand hinge

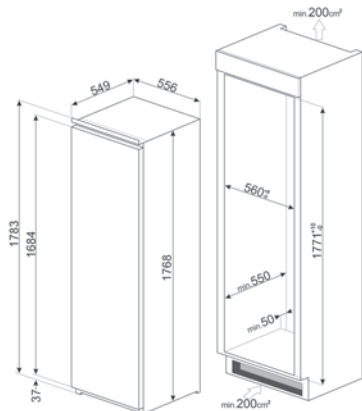

S9F174ND - S9L174ID

S9L174ID

REFRIGERATOR, UNIVERSALE, ONE DOOR,
WHITE



PLUS:



REFRIGERATOR:

Sum of the volumes of the chill compartment(s) and the unfrozen compartment(s): 311 l
Fan assisted
Fan
Internal light in fridge
5 adjustable glass shelves
Glass shelf to cover fruit and vegetable container
Type of crisper/vegetable drawers cover: On sliding rails
Number of fruit and vegetables drawers: 1
Accessories: Kit listeria, Egg tray

INNERDOOR FRIDGE:

No. of door shelves with transparent cover: 1
No. of bottle shelves: 1
Type of compressor: Standard

Annual energy consumption: 114 kWh/a
Electrical connection rating: 100 W
Climatic class: SN, N, ST, T
Airborne acoustical noise emissions: 35 dB(A) re 1pW

Voltage (V): 230-240 V
Current: 0.7 A
Frequency (Hz): 50 Hz

Reversible door with right hand hinges



C875TNE

REFRIGERATOR, UNIVERSALE, BOTTOM MOUNT, BUILT-IN, WHITE



PLUS:



REFRIGERATOR:

Gross Capacity: 370 l
 Sum of the volumes of the chill compartment(s) and the unfrozen compartment(s): 280 l
 Fan assisted refrigerator, no-frost freezer
 Fan
 Internal light in fridge
 3 adjustable glass shelves
 Glass shelf to cover fruit and vegetable container
 Type of crisper/vegetable drawers cover: Standard
 Number of fruit and vegetables drawers: 3
 Accessories: Egg tray

INNERDOOR FRIDGE:

No. of door shelves with transparent cover: 1
 No. of bottle shelves: 1

FREEZER:

Sum of the volumes of the frozen compartment(s): 90 l
 Number of drawers: 3
 Accessories: 1 ice box, 2 eutectics
 Type of compressor: Standard

Annual energy consumption: 247 kWh/a
 Electrical connection rating: 95 W
 Climatic class: SN, N, ST, T
 Airborne acoustical noise emissions: 35 dB(A) re 1pW
 Freezing capacity: 5.2 Kg/24h
 Temperature Rise Time: 9 h

Voltage (V): 230-240 V
 Current: 1.1 A
 Frequency (Hz): 50 Hz

Reversible door with right hand hinges

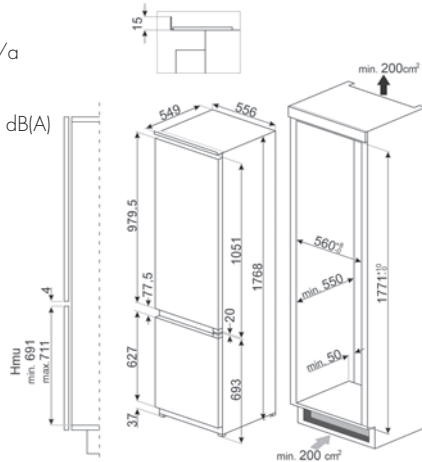

C9174DN2D

REFRIGERATOR, UNIVERSALE, BOTTOM MOUNT, BUILT-IN, WHITE



PLUS:



REFRIGERATOR:

Sum of the volumes of the chill compartment(s) and the unfrozen compartment(s): 187 l
 Fan assisted refrigerator, no-frost freezer
 Fan
 Internal light in fridge
 3 adjustable glass shelves
 Glass shelf to cover fruit and vegetable container
 Type of crisper/vegetable drawers cover: Standard
 Number of fruit and vegetables drawers: 2
 Accessories: Egg tray

INNERDOOR FRIDGE:

No. of door shelves with transparent cover: 1
 No. of bottle shelves: 1

FREEZER:

Sum of the volumes of the frozen compartment(s): 61 l
 Number of drawers: 3
 Accessories: 1 ice box, 2 eutectics
 Type of compressor: Standard

Annual energy consumption: 226 kWh/a
 Electrical connection rating: 140 W
 Climatic class: SN, N, ST, T
 Airborne acoustical noise emissions: 37 dB(A) re 1pW
 Freezing capacity: 10 Kg/24h
 Temperature Rise Time: 23 h

Voltage (V): 230-240 V
 Current: 1.1 A
 Frequency (Hz): 50 Hz

Reversible door with right hand hinges

U8L080DE

REFRIGERATOR, UNIVERSALE, UNDER COUNTER, WHITE



PLUS:



REFRIGERATOR:

Sum of the volumes of the chill compartment(s) and the unfrozen compartment(s): 134 l
 Static
 Internal light in fridge
 3 adjustable glass shelves
 Glass shelf to cover fruit and vegetable container
 Type of crisper/vegetable drawers cover: Standard
 Number of fruit and vegetables drawers: 1
 Accessories: Egg tray

INNERDOOR FRIDGE:

Adjustable door shelves with wire support
 Bottle shelves with wire support
 No. of door shelves with transparent cover: 1
 No. of bottle shelves: 1

Annual energy consumption: 91 kWh/a
 Electrical connection rating: 110 W
 Climatic class: SN, N, ST, T
 Airborne acoustical noise emissions: 37 dB(A) re 1pW

Voltage (V): 230-240 V
 Current: 0.8 A
 Frequency (Hz): 50 Hz

Reversible door with right hand hinges

U8C082DE

REFRIGERATOR, UNIVERSALE, UNDER COUNTER, WHITE



PLUS:



REFRIGERATOR:

Sum of the volumes of the chill compartment(s) and the unfrozen compartment(s): 94 l
 Static
 Internal light in fridge
 2 adjustable glass shelves
 Glass shelf to cover fruit and vegetable container
 Type of crisper/vegetable drawers cover: Standard
 Number of fruit and vegetables drawers: 1
 Accessories: Kit listeria, Egg tray

INNERDOOR FRIDGE:

Adjustable door shelves with wire support
 Bottle shelves with wire support
 No. of door shelves with transparent cover: 1
 No. of bottle shelves: 1

FREEZER:

Sum of the volumes of the frozen compartment(s): 16 l
 Annual energy consumption: 181 kWh/a
 Electrical connection rating: 110 W
 Climatic class: SN, N, ST
 Airborne acoustical noise emissions: 38 dB(A) re 1pW
 Freezing capacity: 2.5 Kg/24h
 Temperature Rise Time: 10 h

Voltage (V): 230-240 V
 Current: 0.9 A
 Frequency (Hz): 50 Hz

Reversible door with right hand hinges

U8F082DE

FREEZERS, UNDER COUNTER, BUILT-IN NICHE: 82-87



PLUS:



Net freezing capacity: 95 l
 Fast freezing button
 Number of drawers: 3
 Power on lamp
 Door on door

Freezing capacity: 17 Kg/24h
 Temperature Rise Time: 20 h
 Climatic class: SN, N, ST, T
 Annual energy consumption: 182 kWh
 Electrical connection rating: 120 W

Frequency (Hz): 50 Hz
 Voltage: 230-240 V
 Current: 0.8 A

Reversible door with right hand hinge

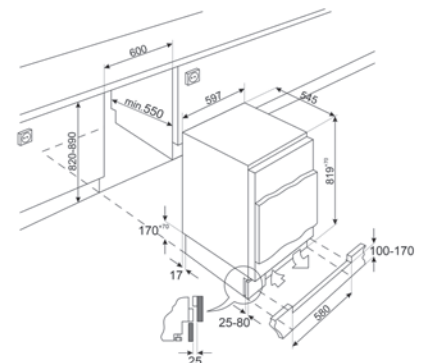

U8L080DF - U8C082DF - U8F082DF1



LVS222BIN

STL7332C

DISHWASHER, FULLY INTEGRATED BUILT-IN,
60 CM, UNIVERSALE, BLACK



PLUS AND OPTIONS:

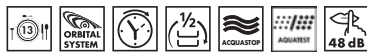

PROGRAMS:



Number of place settings: 13
N. of programmes: 12+2
Orbital
Display: Delayed start, Programme time indicator, Time to end indication, Dynamics programme time indicator, Consumptions
Delay timer option: Up to 24 hours
Visual indicator: salt and rinse aid
Acoustic signal of time to end
1/2 load FlexiZone option
Grey baskets
Height adjustment of the upper basket: On three levels (5 cm)
Upper Basket: With central fixed racks
Lower Basket: With 2 foldable racks
N° baskets: 3, Flexi
Lower basket with anti-drip inserts
Single; cold/hot water max. 60°C - energysave with hot water up to 35%

Energy efficiency class: C

Noise level: 48 dB(A) re 1pW

Current: 10 A
Frequency (Hz): 50 Hz
Voltage: 220-240 V

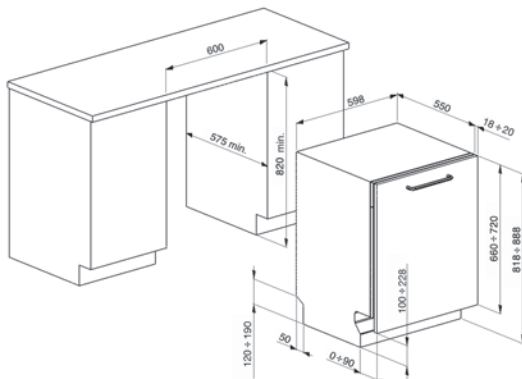

LVS222BIN

DISHWASHER, FREE-STANDING, 60 CM,
UNIVERSALE, WHITE



PLUS AND OPTIONS:



PROGRAMS:



Number of place settings: 13
N. of programmes: 5
Orbital
Delay timer option: 3-6-9 hours
Visual indicator: salt and rinse aid
Light, with acoustic signal of time to end
Grey baskets
Height adjustment of the upper basket: On two levels, by extraction
Upper Basket: With central fixed racks
Lower Basket: With 2 foldable racks
N° baskets: 2
Cutlery basket: 13 place settings sliding
Lower basket with anti-drip inserts
Single; cold/hot water max. 60°C - energysave with hot water up to 35%
Annual water consumption: 3360 l
Annual energy consumption: 259 kWh/a

Noise level: 49 dB(A) re 1pW

Current: 10 A
Frequency (Hz): 50 Hz
Voltage: 220-240 V

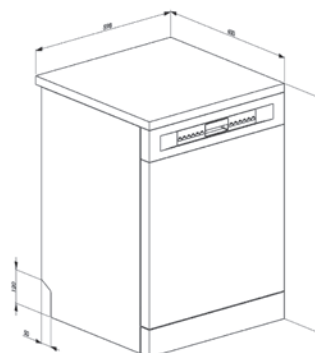



VSTR71DKX

MIDR55CR

TAPS, UNIVERSALE, CHROME



Semi-professional single lever
 Mobile semi-professional
 Double jets
 Aerator
 ESC, WSC
 Flexible hoses length: 500 mm
 Flexible hoses connection: 3/8 "
 Ceramic disc cartridge type: 35 Ø
 Maximum pressure: 5 bar
 Minimum pressure: 1 bar
 Optimal pressure: 3 bar
 Tap hole diameter: 35 mm
 Flexible hoses number: 2
 Holes number: 1
 Swivelling spout
 Swivelling spout rotation: 180 °
 Brass

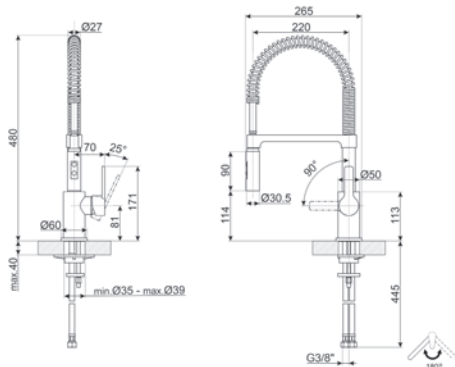

MDF50SS

TAPS, 50'S STYLE, CHROME



Semi-professional single lever
 Mobile semi-professional
 Single jet
 Aerator
 ESC
 Flexible hoses length: 450 mm
 Flexible hoses connection: 3/8 "
 Ceramic disc cartridge type: 25 Ø
 Maximum pressure: 5 bar
 Minimum pressure: 0,5 bar
 Optimal pressure: 3 bar
 Tap hole diameter: 35 mm
 Flexible hoses number: 2
 Holes number: 1
 Swivelling spout
 Swivelling spout rotation: 360 °
 Brass

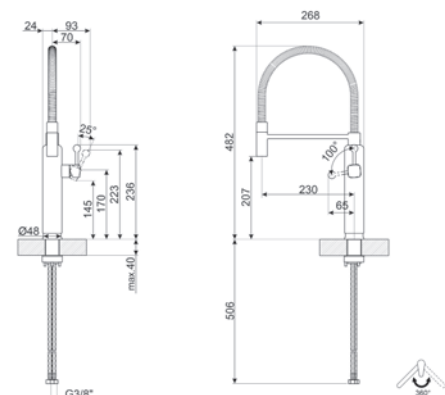

MDF50BL

TAPS, 50'S STYLE, BLACK



Semi-professional single lever
 Mobile semi-professional
 Single jet
 Aerator
 ESC
 Flexible hoses length: 450 mm
 Flexible hoses connection: 3/8 "
 Ceramic disc cartridge type: 25 Ø
 Maximum pressure: 5 bar
 Minimum pressure: 0,5 bar
 Optimal pressure: 3 bar
 Tap hole diameter: 35 mm
 Flexible hoses number: 2
 Holes number: 1
 Swivelling spout
 Swivelling spout rotation: 360 °
 Brass

MDF50CR

TAPS, 50'S STYLE, CREAM



Semi-professional single lever
 Mobile semi-professional
 Single jet
 Aerator
 ESC
 Flexible hoses length: 450 mm
 Flexible hoses connection: 3/8 "
 Ceramic disc cartridge type: 25 Ø
 Maximum pressure: 5 bar
 Minimum pressure: 0,5 bar
 Optimal pressure: 3 bar
 Tap hole diameter: 35 mm
 Flexible hoses number: 2
 Holes number: 1
 Swivelling spout
 Swivelling spout rotation: 360 °
 Brass

MDF50PB

TAPS, 50'S STYLE, PASTEL BLUE



Semi-professional single lever
 Mobile semi-professional
 Single jet
 Aerator
 ESC
 Flexible hoses length: 450 mm
 Flexible hoses connection: 3/8 "
 Ceramic disc cartridge type: 25 Ø
 Maximum pressure: 5 bar
 Minimum pressure: 0,5 bar
 Optimal pressure: 3 bar
 Tap hole diameter: 35 mm
 Flexible hoses number: 2
 Holes number: 1
 Swivelling spout
 Swivelling spout rotation: 360 °
 Brass

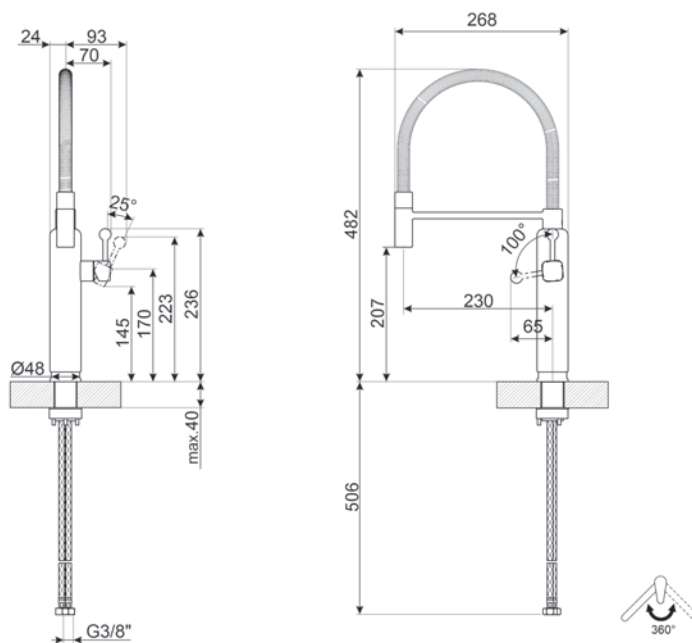

MDF50PG

TAPS, 50'S STYLE, PASTEL GREEN



Semi-professional single lever
Mobile semi-professional
Single jet
Aerator
ESC
Flexible hoses length: 450 mm
Flexible hoses connection: 3/8 "
Ceramic disc cartridge type: 25 Ø
Maximum pressure: 5 bar
Minimum pressure: 0,5 bar
Optimal pressure: 3 bar
Tap hole diameter: 35 mm
Flexible hoses number: 2
Holes number: 1
Swivelling spout
Swivelling spout rotation: 360 °
Brass

MDF50RD

TAPS, 50'S STYLE, RED



Semi-professional single lever
Mobile semi-professional
Single jet
Aerator
ESC
Flexible hoses length: 450 mm
Flexible hoses connection: 3/8 "
Ceramic disc cartridge type: 25 Ø
Maximum pressure: 5 bar
Minimum pressure: 0,5 bar
Optimal pressure: 3 bar
Tap hole diameter: 35 mm
Flexible hoses number: 2
Holes number: 1
Swivelling spout
Swivelling spout rotation: 360 °
Brass

MDF50WH

TAPS, 50'S STYLE, WHITE



Semi-professional single lever
Mobile semi-professional
Single jet
Aerator
ESC
Flexible hoses length: 450 mm
Flexible hoses connection: 3/8 "
Ceramic disc cartridge type: 25 Ø
Maximum pressure: 5 bar
Minimum pressure: 0,5 bar
Optimal pressure: 3 bar
Tap hole diameter: 35 mm
Flexible hoses number: 2
Holes number: 1
Swivelling spout
Swivelling spout rotation: 360 °
Brass

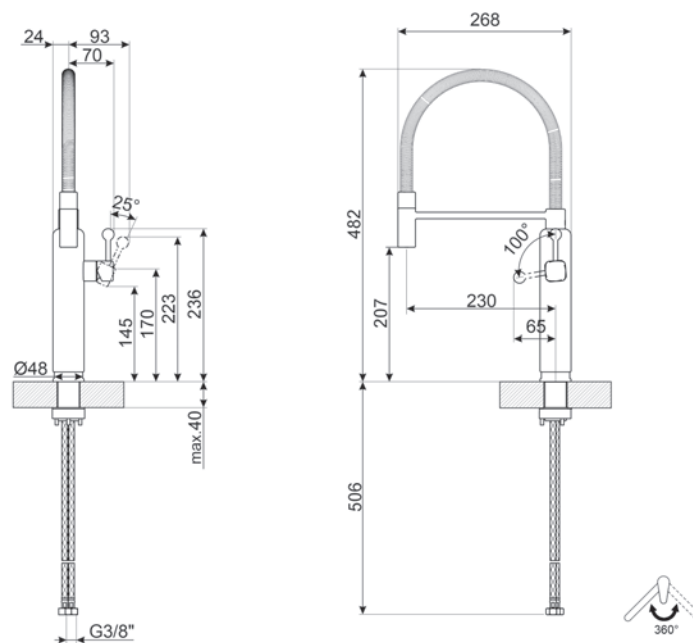

MID6SS

TAPS, UNIVERSALE, STAINLESS STEEL

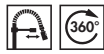

Semi-professional single lever
 Mobile semi-professional
 Single jet
 Aerator
 Flexible hoses lenght: 700 mm
 Flexible hoses connection: 3/8 "
 Ceramic disc cartridge type: 25 Ø
 Maximum pressure: 5 bar
 Minimum pressure: 1 bar
 Optimal pressure: 3 bar
 Tap hole diameter: 35 mm
 Flexible hoses number: 2
 Holes number: 1
 Swivelling spout
 Swivelling spout rotation: 360 °
 Stainless steel AISI 316

MID6DKX

TAPS, UNIVERSALE, DARK INOX

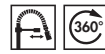

Semi-professional single lever
 Mobile semi-professional
 Single jet
 Aerator
 Flexible hoses lenght: 700 mm
 Flexible hoses connection: 3/8 "
 Ceramic disc cartridge type: 25 Ø
 Maximum pressure: 5 bar
 Minimum pressure: 1 bar
 Optimal pressure: 3 bar
 Tap hole diameter: 35 mm
 Flexible hoses number: 2
 Holes number: 1
 Swivelling spout
 Swivelling spout rotation: 360 °
 Stainless steel AISI 316

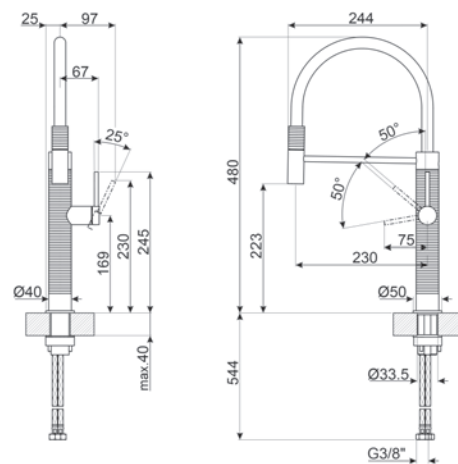
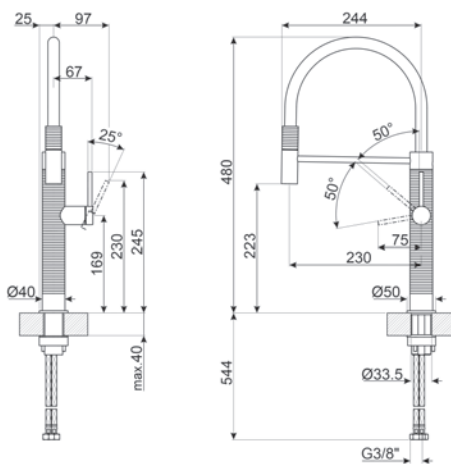

MD22DKX

TAPS, UNIVERSALE, DARK INOX

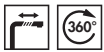

Single lever
 Extractable
 Single jet
 Aerator
 Flexible hoses lenght: 450 mm
 Flexible hoses connection: 3/8 "
 Ceramic disc cartridge type: 25 Ø
 Maximum pressure: 5 bar
 Minimum pressure: 0,5 bar
 Optimal pressure: 3 bar
 Tap hole diameter: 35 mm
 Flexible hoses number: 2
 Holes number: 1
 Swivelling spout
 Swivelling spout rotation: 360 °
 Brass

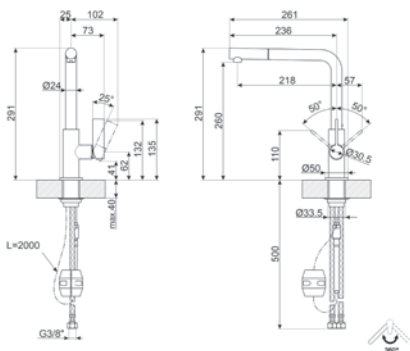

MAP99CR

TAPS, UNIVERSALE, CHROME



Double lever filtered water
 Single jet
 Aerator
 ESC
 Flexible hoses lenght: 360 mm
 Flexible hoses connection: 3/8 "
 Ceramic disc cartridge type: 35 Ø
 Filtered water cartridge type: 20x1
 Water depuration filter
 Maximum pressure: 10 bar
 Minimum pressure: 0,5 bar
 Optimal pressure: 3 bar
 Tap hole diameter: 35 mm
 Handle for filtered water supply
 Flexible hoses number: 3
 Holes number: 1
 Swivelling spout
 Swivelling spout rotation: 360 °
 Brass

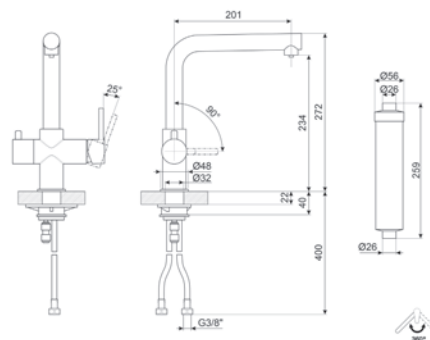

MTD5CR

TAPS, UNIVERSALE, CHROME

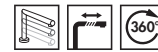

Remote lever and telescopic mixer
 Extractable
 Single jet
 Aerator
 Flexible hoses lenght: 500 mm
 Flexible hoses connection: 3/8 "
 Ceramic disc cartridge type: 25 Ø
 Maximum pressure: 5 bar
 Minimum pressure: 0,5 bar
 Optimal pressure: 3 bar
 Tap hole diameter: 35 mm
 Flexible hoses number: 2
 Holes number: 2
 Swivelling spout
 Swivelling spout rotation: 360 °
 Brass

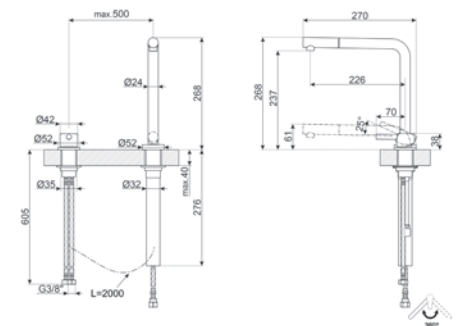



A5-81

A5-81

COOKER, CLASSICA, OPERA, 150X60 CM, STAINLESS STEEL



HOBS:



Gas

Total no. of cook zones: 7

Front left: 4.20 kW

Rear left: 1.80 kW

Front centre: 1.00 kW

Rear centre: 3.00 kW

Front right: 1.00 kW

Rear right: 1.90 kW

Right: 5.00 kW

Central: 1.60 (BBQ) kW

Burner caps: Matt black enamelled

Cast Iron

Gas safety valves

Automatic switch off when overflow

Wok stand

G30 LPG liquid gas

MAIN OVEN:



Net volume of the cavity: 77 l

Cooling system: Tangential

Display: Touch

Start and Stop

End of cooking acoustic alarm

Temperature: from 50 to 250 °C

Maximum temperature: 250 °C

Light when oven door is open

2 lamps, power 25 W

Metal racks, 4 cooking levels

Roof Liner

Grill type: Electric

No. of thermo-reflective door glasses: 2

Removable inner door

Gas safety valves

Frequency: 50/60 Hz

Gas

Voltage: 220-240 V

G30 LPG liquid gas

Wide baking tray: 2

TOP Oven grid with back stop: 2

SECONDARY OVEN:

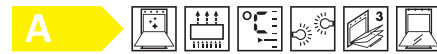

Net volume of the second cavity: 54 l

Cooling system: Tangential

Cooking time setting

End of cooking acoustic alarm

Maximum temperature: 280 °C

Light when oven door is open

1 halogen lamp, power 40 W

Metal racks, 4 cooking levels

Grill type: Electric

No. thermo-reflective door glasses: 2

Catalytic panels: 3

Grill mesh: 1

Rack with back and side stop: 1

Refractory stone + cover + shovel

Drawer

Frequency: 50/60 Hz

Current: 34 A

Voltage: 220-240 V

Voltage 2 (V): 380-415 V

Electrical connection rating: 7700 W

Gas connection rating (W): 17400 W

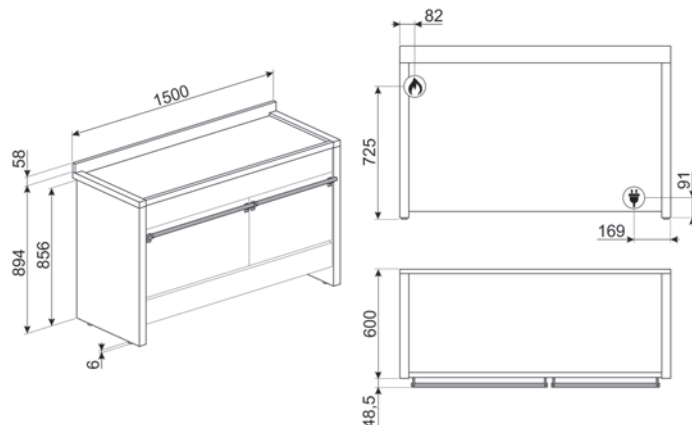

A3-81

COOKER, CLASSICA, OPERA, 120X60 CM, STAINLESS STEEL



HOBS:



Gas

Total no. of cook zones: 6

Front left: 4.20 kW

Rear left: 1.80 kW

Front centre: 1.00 kW

Rear centre: 3.00 kW

Front right: 1.00 kW

Rear right: 1.90 kW

Central: 1.60 (BBQ) kW

Burner caps: Matt black enamelled

Cast Iron

Gas safety valves

Wok stand

G30 LPG liquid gas

MAIN OVEN:

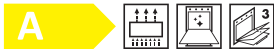

Net volume of the cavity: 77 l

Cooling system: Tangential

Display: Touch

Start and Stop

End of cooking acoustic alarm

Temperature: from 50 to 250 °C

Maximum temperature: 250 °C

Light when oven door is open

2 lamps, power 25 W

Metal racks, 4 cooking levels

Grill type: Electric

No. of thermo-reflective door glasses: 2

Gas safety valves

Frequency: 50/60 Hz

Gas

Voltage: 220-240 V

G30 LPG liquid gas

Wide baking tray: 2

TOP Oven grid with back stop: 2

SECONDARY OVEN:

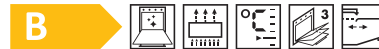

Net volume of the second cavity: 40 l

Cooling system: Tangential

Temperature: from 50 to 220 °C

Maximum temperature: 220 °C

Light when oven door is open

1 lamp, power 25 W

Metal racks, 4 cooking levels

Roof Liner

Grill type: Electric

No. thermo-reflective door glasses: 2

Wide baking tray: 1

Grill mesh: 1

Rack with back and side stop: 1

Drawer

Frequency: 50/60 Hz

Current: 30 A

Voltage: 220-240 V

Voltage 2 (V): 380-415 V

Electrical connection rating: 6800 W

Gas connection rating (W): 12700 W

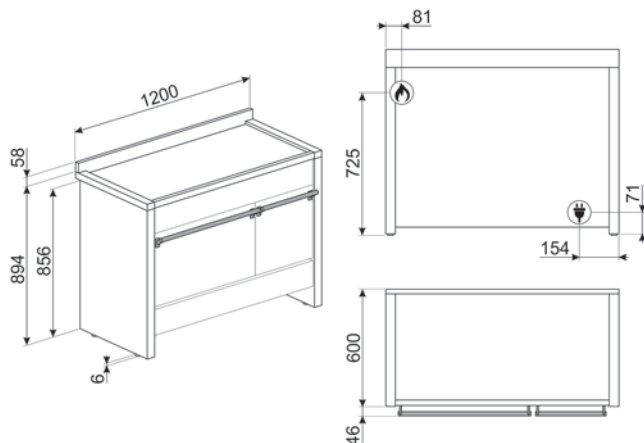

A1-9

COOKER, CLASSICA, OPERA, 90X60 CM,
STAINLESS STEEL



HOBS:



Gas
Total no. of cook zones: 6
Front left: 4.20 kW
Rear left: 3.00 kW
Front centre: 1.00 kW
Rear centre: 1.80 kW
Front right: 1.80 kW
Rear right: 3.00 kW
Burner caps: Matt black enamelled
Cast Iron
Gas safety valves
Cast iron wok support: 1
G30 LPG liquid gas

Frequency: 50/60 Hz
Current: 14 A
Voltage: 220-240 V
Electrical connection rating: 3200 W
Gas connection rating (W): 14500 W

MAIN OVEN:

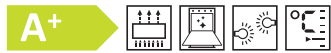

Net volume of the cavity: 115 l
Cooling system: Tangential
Display: TFT
Start and Stop
End of cooking acoustic alarm
Catalytic
Temperature: from 50 to 280 °C
Maximum temperature: 280 °C
Heating suspended when door is opened
Light when oven door is open
2 halogen lamps, power 40 W
Metal racks, 5 cooking levels
Grill type: Electric
No. of thermo-reflective door glasses: 2
Removable inner door
Gas safety valves
Frequency: 50/60 Hz
Gas
Voltage: 220-240 V
G30 LPG liquid gas
Catalytic panels: 3
Grill mesh: 1
Rack with back and side stop: 1



Drawer

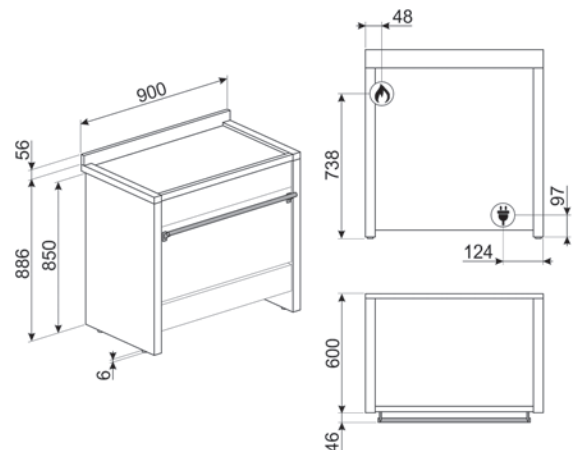



CPF120IGMPR

CPF120IGMPBL

COOKER, PORTOFINO, 120X60 CM, BLACK



HOBS:



Mixed

Total no. of cook zones: 6

Selected zone indicator

Centrale sinistra: 4.20 kW

Front centre: 1.80 kW

Rear centre: 3.00 kW

Front right: 21.1x19.1 cm, 2.10 kW - 2.30 kW

Rear right: 21.0x19.0 cm, 1.60 kW - 1.85 kW

Central: 1.40 kW

Burner caps: Matt black enamelled

Cast Iron

Gas safety valves

Automatic switch off when overheat

Minimum pan diameter indication

Automatic pan detection

G30 LPG liquid gas

MAIN OVEN:



Net volume of the cavity: 70 l

Cooling system: Tangential

Display: Touch

Start and Stop

End of cooking acoustic alarm

Pyrolytic

Temperature: from 50 to 280 °C

Maximum temperature: 280 °C

Heating suspended when door is opened

Door Lock During Pyrolysis

Light when oven door is open

2 halogen lamps, power 40 W

Metal racks, 5 cooking levels

Grill type: Electric

No. of thermo-reflective door glasses: 3

Removable inner door

Gas safety valves

Frequency: 50/60 Hz

Mixed

Voltage: 220-240 V

G30 LPG liquid gas

Grill mesh: 1

Rack with back and side stop: 1

CPF120IGMPR

COOKER, PORTOFINO, 120X60 CM, RED



SECONDARY OVEN:



Net volume of the second cavity: 63 l

Cooling system: Tangential

Cooking time setting

End of cooking acoustic alarm

Temperature: from 50 to 260 °C

Maximum temperature: 260 °C

Heating suspended when door is opened

Light when oven door is open

2 halogen lamps, power 40 W

Metal racks, 5 cooking levels

Grill type: Electric

No. thermo-reflective door glasses: 2

Grill mesh: 1

Rack with back and side stop: 1

Drawer

Frequency: 50/60 Hz

Current: 32 A

Voltage: 220-240 V

Voltage 2 (V): 380-415 V

Electrical connection rating: 10900 W

Gas connection rating (W): 9000 W

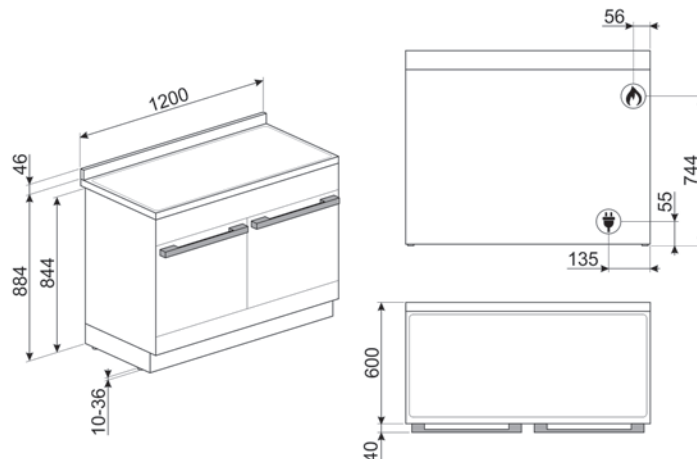

CPF120IGMPT

COOKER, PORTOFINO, 120X60 CM, TURQUESE



HOBS:



Mixed

Total no. of cook zones: 6

Selected zone indicator

Centrale sinistra: 4.20 kW

Front centre: 1.80 kW

Rear centre: 3.00 kW

Front right: 21.1x19.1 cm, 2.10 kW - 2.30 kW

Rear right: 21.0x19.0 cm, 1.60 kW - 1.85 kW

Central: 1.40 kW

Burner caps: Matt black enamelled

Cast Iron

Gas safety valves

Automatic switch off when overheat

Minimum pan diameter indication

Automatic pan detection

G30 LPG liquid gas

MAIN OVEN:



Net volume of the cavity: 70 l

Cooling system: Tangential

Display: Touch

Start and Stop

End of cooking acoustic alarm

Pyrolytic

Temperature: from 50 to 280 °C

Maximum temperature: 280 °C

Heating suspended when door is opened

Door Lock During Pyrolysis

Light when oven door is open

2 halogen lamps, power 40 W

Metal racks, 5 cooking levels

Grill type: Electric

No. of thermo-reflective door glasses: 3

Removable inner door

Gas safety valves

Frequency: 50/60 Hz

Mixed

Voltage: 220-240 V

G30 LPG liquid gas

Grill mesh: 1

Rack with back and side stop: 1

CPF120IGMPWH

COOKER, PORTOFINO, 120X60 CM, WHITE



SECONDARY OVEN:

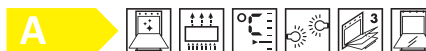

Net volume of the second cavity: 63 l

Cooling system: Tangential

Cooking time setting

End of cooking acoustic alarm

Temperature: from 50 to 260 °C

Maximum temperature: 260 °C

Heating suspended when door is opened

Light when oven door is open

2 halogen lamps, power 40 W

Metal racks, 5 cooking levels

Grill type: Electric

No. thermo-reflective door glasses: 2

Grill mesh: 1

Rack with back and side stop: 1

Drawer

Frequency: 50/60 Hz

Current: 32 A

Voltage: 220-240 V

Voltage 2 (V): 380-415 V

Electrical connection rating: 10900 W

Gas connection rating (W): 9000 W

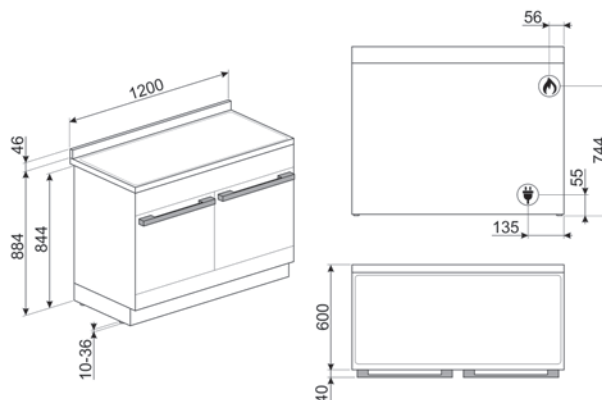

CPF120IGMPX

COOKER, PORTOFINO, 120X60 CM, STAINLESS STEEL



HOB'S:



Mixed

Total no. of cook zones: 6

Selected zone indicator

Centrale sinistra: 4.20 kW

Front centre: 1.80 kW

Rear centre: 3.00 kW

Front right: 21.1x19.1 cm, 2.10 kW - 2.30 kW

Rear right: 21.0x19.0 cm, 1.60 kW - 1.85 kW

Central: 1.40 kW

Burner caps: Matt black enamelled

Cast Iron

Gas safety valves

Automatic switch off when overheat

Minimum pan diameter indication

Automatic pan detection

G30 LPG liquid gas

MAIN OVEN:



Net volume of the cavity: 70 l

Cooling system: Tangential

Display: Touch

Start and Stop

End of cooking acoustic alarm

Pyrolytic

Temperature: from 50 to 280 °C

Maximum temperature: 280 °C

Heating suspended when door is opened

Door Lock During Pyrolysis

Light when oven door is open

2 halogen lamps, power 40 W

Metal racks, 5 cooking levels

Grill type: Electric

No. of thermo-reflective door glasses: 3

Removable inner door

Gas safety valves

Frequency: 50/60 Hz

Mixed

Voltage: 220-240 V

G30 LPG liquid gas

Grill mesh: 1

Rack with back and side stop: 1

SECONDARY OVEN:

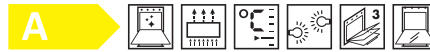

Net volume of the second cavity: 63 l

Cooling system: Tangential

Cooking time setting

End of cooking acoustic alarm

Temperature: from 50 to 260 °C

Maximum temperature: 260 °C

Heating suspended when door is opened

Light when oven door is open

2 halogen lamps, power 40 W

Metal racks, 5 cooking levels

Grill type: Electric

No. thermo-reflective door glasses: 2

Grill mesh: 1

Rack with back and side stop: 1

Drawer

Frequency: 50/60 Hz

Current: 32 A

Voltage: 220-240 V

Voltage 2 (V): 380-415 V

Electrical connection rating: 10900 W

Gas connection rating (W): 9000 W

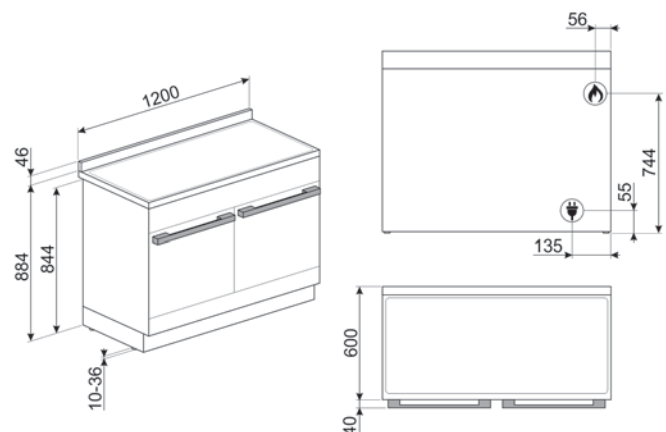

CPF9GPAN

COOKER, PORTOFINO, 90X60 CM, ANTHRACITE



CPF9GPBL

COOKER, PORTOFINO, 90X60 CM, BLACK



CPF9GPOG

COOKER, PORTOFINO, 90X60 CM, OLIVE GREEN



HOBS:



Gas

Total no. of cook zones: 6

Front left: 4.20 kW

Rear left: 1.00 kW

Front centre: 1.00 kW

Rear centre: 1.80 kW

Front right: 1.80 kW

Rear right: 3.00 kW

Burner caps: Matt black enamelled

Cast iron

Gas safety valves

Cast iron wok support: 1

G30 LPG liquid gas

Frequency: 50/60 Hz

Current: 18 A

Voltage: 220-240 V

Voltage 2 (V): 380-415 V

Electrical connection rating: 4000 W

Gas connection rating (W): 12500 W

CPF9GPOR

COOKER, PORTOFINO, 90X60 CM, ORANGE



MAIN OVEN:

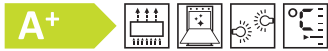

Net volume of the cavity: 115 l

Cooling system: Tangential

Display: LCD

Start and Stop

End of cooking acoustic alarm

Pyrolytic

Temperature: from 50 to 260 °C

Maximum temperature: 260 °C

Heating suspended when door is opened

Door Lock During Pyrolysis

Light when oven door is open

2 halogen lamps, power 40 W

Metal racks, 5 cooking levels

Grill type: Electric

No. of thermo-reflective door glasses: 3

Removable inner door

Gas safety valves

Frequency: 50/60 Hz

Gas

Voltage: 220-240 V

G30 LPG liquid gas

Grill mesh: 1

Rack with back and side stop: 1



Push pull

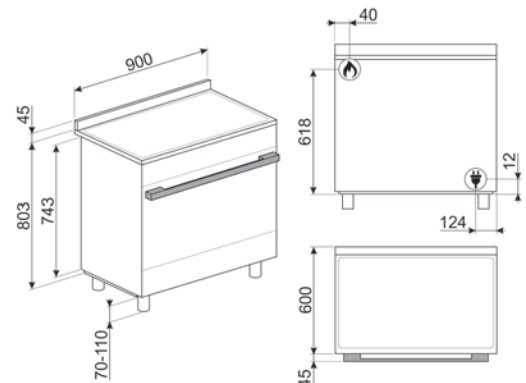

CPF9GPR

COOKER, PORTOFINO, 90X60 CM, RED



HOBBS:



Gas

Total no. of cook zones: 6

Front left: 4.20 kW

Rear left: 1.00 kW

Front centre: 1.00 kW

Rear centre: 1.80 kW

Front right: 1.80 kW

Rear right: 3.00 kW

Burner caps: Matt black enamelled

Cast iron

Gas safety valves

Cast iron wok support: 1

G30 LPG liquid gas

MAIN OVEN:

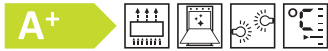

Net volume of the cavity: 115 l

Cooling system: Tangential

Display: LCD

Start and Stop

End of cooking acoustic alarm

Pyrolytic

Temperature: from 50 to 260 °C

Maximum temperature: 260 °C

Heating suspended when door is opened

Door Lock During Pyrolysis

Light when oven door is open

2 halogen lamps, power 40 W

Metal racks, 5 cooking levels

Grill type: Electric

No. of thermo-reflective door glasses: 3

Removable inner door

Gas safety valves

Frequency: 50/60 Hz

Gas

Voltage: 220-240 V

G30 LPG liquid gas

Grill mesh: 1

Rack with back and side stop: 1



Push pull

CPF9GPWH

COOKER, PORTOFINO, 90X60 CM, WHITE



Frequency: 50/60 Hz

Current: 18 A

Voltage: 220-240 V

Voltage 2 (V): 380-415 V

Electrical connection rating: 4000 W

Gas connection rating (W): 12500 W

CPF9GPX

COOKER, PORTOFINO, 90X60 CM, STAINLESS STEEL



CPF9GPYW

COOKER, PORTOFINO, 90X60 CM, YELLOW

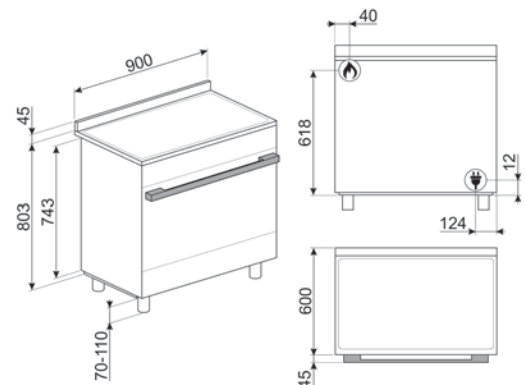



TR90P2

TR90GMP

COOKER, VICTORIA, 90X60 CM, CREAM



HOBS:



Gas
 Total no. of cook zones: 5
 Front left: 2.90 kW
 Rear left: 1.80 kW
 Central: 5.00 kW
 Rear right: 1.80 kW
 Front right: 1.00 kW
 Burner caps: Matt black enamelled
 Cast Iron
 Gas safety valves
 Moka stand in cast iron: 1
 Cast iron wok support: 1
 G30 LPG liquid gas

MAIN OVEN:

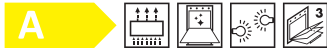

Net volume of the cavity: 115 l
 Cooling system: Tangential
 Display: electronic 5 buttons
 Start and Stop
 End of cooking acoustic alarm
 Catalytic
 Temperature: from 50 to 260 °C
 Maximum temperature: 260 °C
 Light when oven door is open
 2 halogen lamps, power 40 W
 Metal racks, 5 cooking levels
 Grill type: Electric
 No. of thermo-reflective door glasses: 2
 Removable inner door
 Gas safety valves
 Frequency: 50/60 Hz
 Gas
 Voltage: 220-240 V
 G30 LPG liquid gas
 Catalytic panels: 3
 Grill mesh: 1
 Rack with back and side stop: 1



Drawer

TR90GMB2

COOKER, VICTORIA, 90X60 CM, BLACK



Frequency: 50/60 Hz
 Current: 14 A
 Voltage: 220-240 V
 Electrical connection rating: 3200 W
 Gas connection rating (W): 12300 W

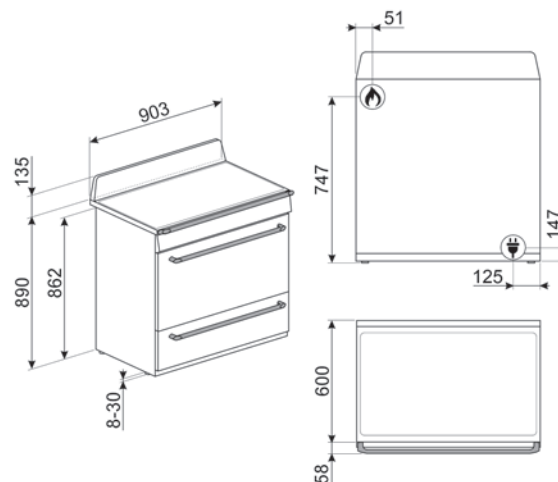



FAB38RBL5

FAB38RBL6

REFRIGERATOR, 50'S STYLE, BOTTOM MOUNT, FREE STANDING, BLACK



FAB38RCR6

REFRIGERATOR, 50'S STYLE, BOTTOM MOUNT, FREE STANDING, CREAM



FAB38RPB6

REFRIGERATOR, 50'S STYLE, BOTTOM MOUNT, FREE STANDING, PASTEL BLUE



PLUS:

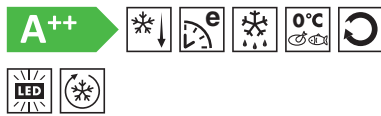

REFRIGERATOR:

Sum of the volumes of the chill compartment(s) and the unfrozen compartment(s): 344 l
 Total No Frost - Double Cooling system
 Fan
 MultiFlow
 Internal light in fridge
 Life Plus zone-0°C
 3 adjustable glass shelves
 Glass shelf to cover fruit and vegetable container
 Type of crisper/vegetable drawers cover: On sliding rails
 Number of fruit and vegetables drawers: 1

INNERDOOR FRIDGE:

No. of bottle shelves: 1

FREEZER:

Sum of the volumes of the frozen compartment(s): 137 l
 Number of drawers: 2
 Fast freezing compartment
 Type of shelves: Glass
 No. of compartments with flap: 1
 Manual ice maker

Fast freezing button
 Type of compressor: Inverter

Annual energy consumption: 321 kWh/a
 Electrical connection rating: 127 W
 Climatic class: SN, N, ST, T
 Airborne acoustical noise emissions: 41 dB(A) re 1pW
 Freezing capacity: 8 Kg/24h
 Temperature Rise Time: 14 h

Voltage (V): 220-240 V
 Current: 1.1 A
 Frequency (Hz): 50/60 Hz

Right hand hinges

Dimensions: 2050x706x771 mm

Right hand hinges

Right hand hinges

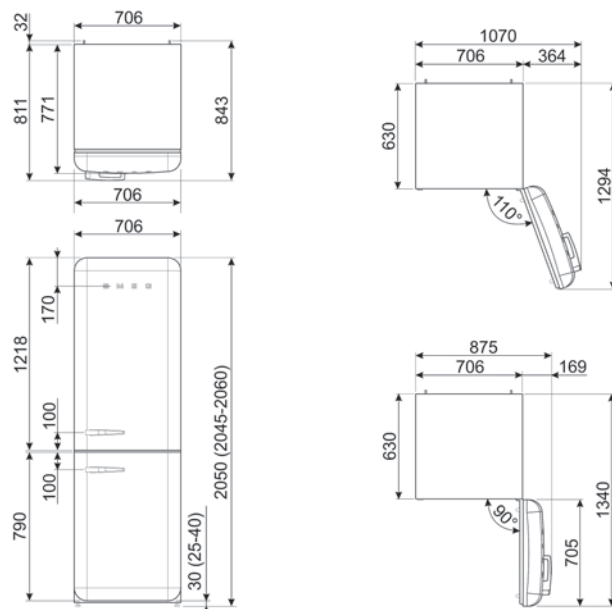

FAB38RPG6

REFRIGERATOR, 50'S STYLE, BOTTOM MOUNT, FREE STANDING, PASTEL GREEN



FAB38RRD6

REFRIGERATOR, 50'S STYLE, BOTTOM MOUNT, FREE STANDING, RED



FAB38RWH6

REFRIGERATOR, 50'S STYLE, BOTTOM MOUNT, FREE STANDING, WHITE



PLUS:



REFRIGERATOR:

Sum of the volumes of the chill compartment(s) and the unfrozen compartment(s): 344 l
 Total No Frost - Double Cooling system
 Fan
 MultiFlow
 Internal light in fridge
 Life Plus zone-0°C
 3 adjustable glass shelves
 Glass shelf to cover fruit and vegetable container
 Type of crisper/vegetable drawers cover: On sliding rails
 Number of fruit and vegetables drawers: 1

INNERDOOR FRIDGE:

No. of bottle shelves: 1

FREEZER:

Sum of the volumes of the frozen compartment(s): 137 l
 Number of drawers: 2
 Fast freezing compartment
 Type of shelves: Glass
 No. of compartments with flap: 1
 Manual ice maker

Fast freezing button
 Type of compressor: Inverter

Annual energy consumption: 321 kWh/a
 Electrical connection rating: 127 W
 Climatic class: SN, N, ST, T
 Airborne acoustical noise emissions: 41 dB(A) re 1pW
 Freezing capacity: 8 Kg/24h
 Temperature Rise Time: 14 h

Voltage (V): 220-240 V
 Current: 1.1 A
 Frequency (Hz): 50/60 Hz

Right hand hinges

Dimensions: 2050x706x771 mm

Right hand hinges

Right hand hinges

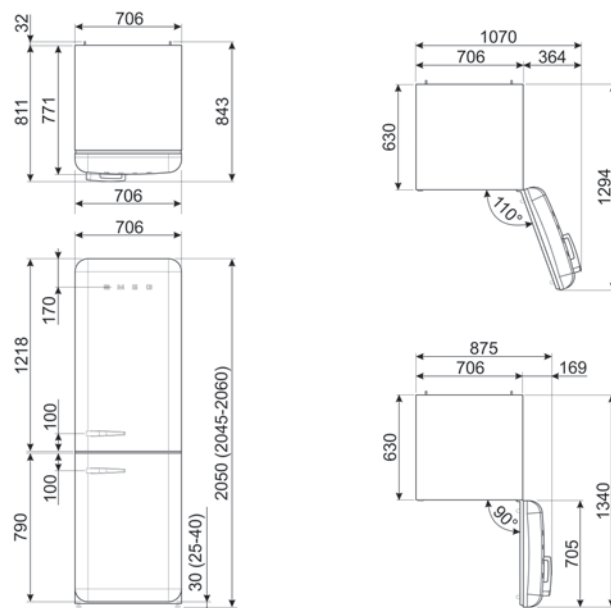



FAB50RCR5

FAB50RBL5

REFRIGERATOR, 50'S STYLE, DOUBLE DOOR, FREE STANDING, BLACK



FAB50RCR5

REFRIGERATOR, 50'S STYLE, DOUBLE DOOR, FREE STANDING, CREAM



FAB50RCRB5

REFRIGERATOR, 50'S STYLE, DOUBLE DOOR, FREE STANDING, CREAM



PLUS:

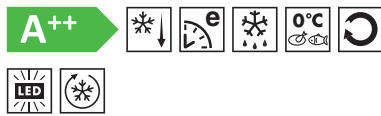

REFRIGERATOR:

Sum of the volumes of the chill compartment(s) and the unfrozen compartment(s): 400 l
 Total No Frost - Double Cooling system
 Fan
 MultiFlow
 Internal light in fridge
 Life Plus zone-0°C
 2 adjustable glass shelves
 Glass shelf to cover fruit and vegetable container
 Type of crisper/vegetable drawers cover: Standard
 Number of fruit and vegetables drawers: 1

INNERDOOR FRIDGE:

No. of bottle shelves: 1

FREEZER:

Sum of the volumes of the frozen compartment(s): 124 l
 Type of internal light (freezer): LED
 Internal light in freezer
 Fast freezing compartment
 Type of shelves: Glass
 Manual ice maker

Fast freezing button
 Type of compressor: Inverter

Annual energy consumption: 328 kWh/a
 Electrical connection rating: 197 W
 Climatic class: SN, N, ST, T
 Airborne acoustical noise emissions: 41 dB(A) re 1pW
 Freezing capacity: 6 Kg/24h
 Temperature Rise Time: 15 h

Voltage (V): 220-240 V
 Current: 1.1 A
 Frequency (Hz): 50/60 Hz

Right hand hinges

Dimensions: 1921x796x805 mm

Right hand hinges

Right hand hinges

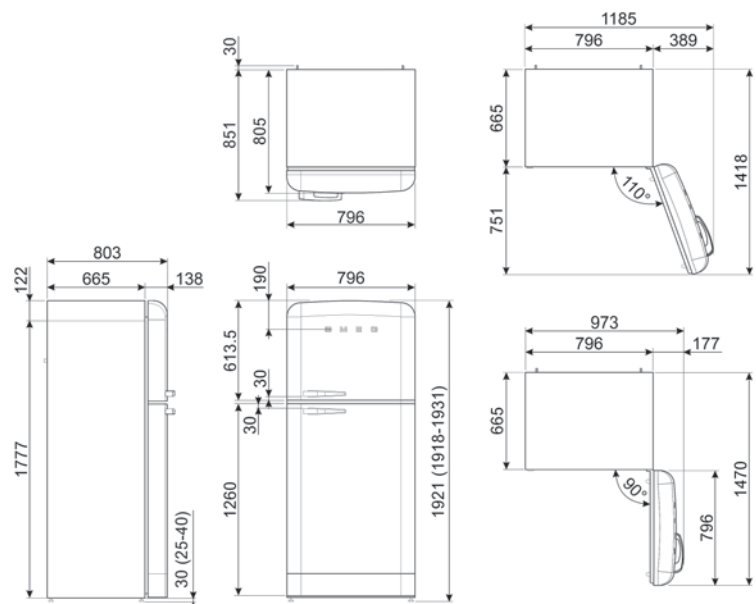

FAB50RPB5

REFRIGERATOR, 50'S STYLE, DOUBLE DOOR,
FREE STANDING, PASTEL BLUE



FAB50RPG5

REFRIGERATOR, 50'S STYLE, DOUBLE DOOR,
FREE STANDING, PASTEL GREEN



FAB50RRD5

REFRIGERATOR, 50'S STYLE, DOUBLE DOOR,
FREE STANDING, RED



PLUS:

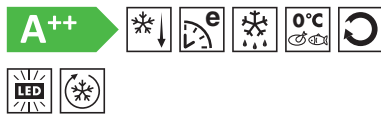

REFRIGERATOR:

Sum of the volumes of the chill compartment(s)
and the unfrozen compartment(s): 400 l
Total No Frost - Double Cooling system
Fan
MultiFlow
Internal light in fridge
Life Plus zone-0°C
2 adjustable glass shelves
Glass shelf to cover fruit and vegetable
container
Type of crisper/vegetable drawers cover:
Standard
Number of fruit and vegetables drawers: 1

INNERDOOR FRIDGE:

No. of bottle shelves: 1

FREEZER:

Sum of the volumes of the frozen
compartment(s): 124 l
Type of internal light (freezer): LED
Internal light in freezer
Fast freezing compartment
Type of shelves: Glass
Manual ice maker

Fast freezing button
Type of compressor: Inverter

Annual energy consumption: 328 kWh/a
Electrical connection rating: 197 W
Climatic class: SN, N, ST, T
Airborne acoustical noise emissions: 41 dB(A)
re 1pW
Freezing capacity: 6 Kg/24h
Temperature Rise Time: 15 h

Voltage (V): 220-240 V
Current: 1.1 A
Frequency (Hz): 50/60 Hz

Right hand hinges

Dimensions: 1921x796x805 mm

Right hand hinges

Right hand hinges

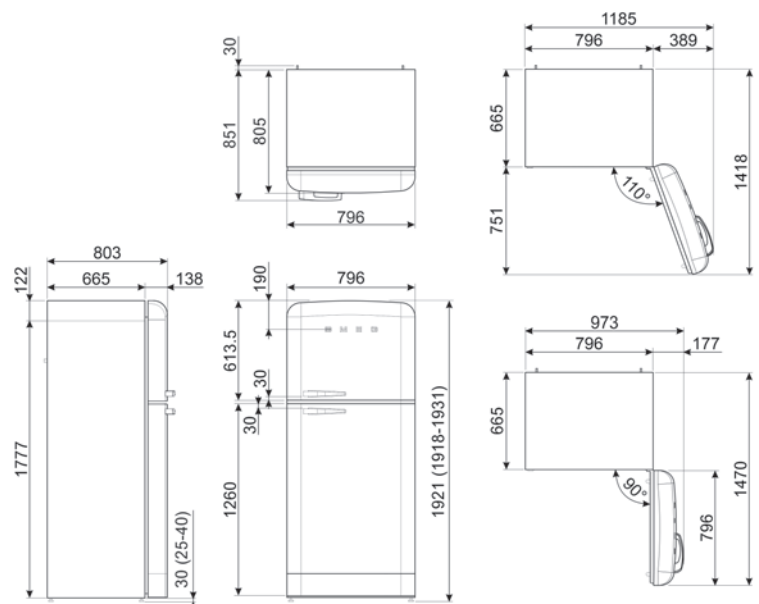



FAB32RBE5

FAB32RBE5

REFRIGERATOR, 50'S STYLE, BOTTOM MOUNT, FREE STANDING, BLUE



FAB32RBL5

REFRIGERATOR, 50'S STYLE, BOTTOM MOUNT, FREE STANDING, BLACK



FAB32RCR5

REFRIGERATOR, 50'S STYLE, BOTTOM MOUNT, FREE STANDING, CREAM



PLUS:

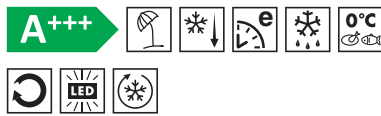

REFRIGERATOR:

Sum of the volumes of the chill compartment(s) and the unfrozen compartment(s): 234 l
 Total No Frost - Double Cooling system
 Fan
 MultiFlow
 Internal light in fridge
 Life Plus zone-0°C
 2 adjustable glass shelves
 Glass shelf to cover fruit and vegetable container
 Type of crisper/vegetable drawers cover: On sliding rails
 Number of fruit and vegetables drawers: 1

INNERDOOR FRIDGE:

Adjustable door shelves with wire support
 Bottle shelves with wire support
 No. of door shelves with transparent cover: 1
 No. of bottle shelves: 1

FREEZER:

Sum of the volumes of the frozen compartment(s): 97 l
 Number of drawers: 3
 Fast freezing compartment
 Type of shelves: Glass

Fast freezing button
 Type of compressor: Inverter

Annual energy consumption: 178 kWh/a
 Electrical connection rating: 127 W
 Climatic class: SN, N, ST, T
 Airborne acoustical noise emissions: 37 dB(A) re 1pW
 Freezing capacity: 6 Kg/24h
 Temperature Rise Time: 40 h

Voltage (V): 220-240 V
 Current: 0.80 A
 Frequency (Hz): 50/60 Hz

Right hand hinges

Right hand hinges

Right hand hinges

Dimensions: 1968x601x728 mm

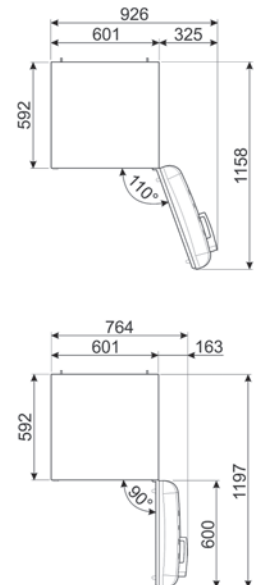
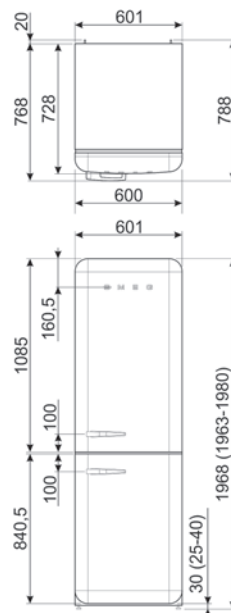

FAB32RLI5

REFRIGERATOR, 50'S STYLE, BOTTOM MOUNT, FREE STANDING, LIME GREEN



FAB32ROR5

REFRIGERATOR, 50'S STYLE, BOTTOM MOUNT, FREE STANDING, ORANGE



FAB32RPB5

REFRIGERATOR, 50'S STYLE, BOTTOM MOUNT, FREE STANDING, PASTEL BLUE



PLUS:

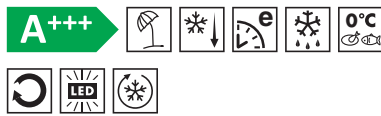

REFRIGERATOR:

Sum of the volumes of the chill compartment(s) and the unfrozen compartment(s): 234 l
 Total No Frost - Double Cooling system
 Fan
 MultiFlow
 Internal light in fridge
 Life Plus zone-0°C
 2 adjustable glass shelves
 Glass shelf to cover fruit and vegetable container
 Type of crisper/vegetable drawers cover: On sliding rails
 Number of fruit and vegetables drawers: 1

INNERDOOR FRIDGE:

Adjustable door shelves with wire support
 Bottle shelves with wire support
 No. of door shelves with transparent cover: 1
 No. of bottle shelves: 1

FREEZER:

Sum of the volumes of the frozen compartment(s): 97 l
 Number of drawers: 3
 Fast freezing compartment
 Type of shelves: Glass

Fast freezing button
 Type of compressor: Inverter

Annual energy consumption: 178 kWh/a
 Electrical connection rating: 127 W
 Climatic class: SN, N, ST, T
 Airborne acoustical noise emissions: 37 dB(A) re 1pW
 Freezing capacity: 6 Kg/24h
 Temperature Rise Time: 40 h

Voltage (V): 220-240 V
 Current: 0.80 A
 Frequency (Hz): 50/60 Hz

Right hand hinges

Right hand hinges

Right hand hinges

Dimensions: 1968x601x728 mm

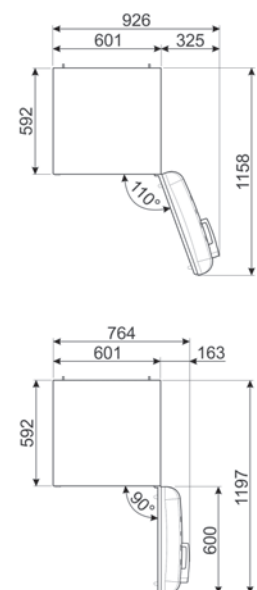
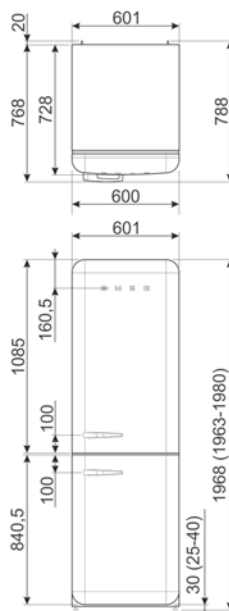

FAB32RPG5

REFRIGERATOR, 50'S STYLE, BOTTOM MOUNT, FREE STANDING, PASTEL GREEN



FAB32RPK5

REFRIGERATOR, 50'S STYLE, BOTTOM MOUNT, FREE STANDING, PINK



FAB32RRD5

REFRIGERATOR, 50'S STYLE, BOTTOM MOUNT, FREE STANDING, RED



PLUS:

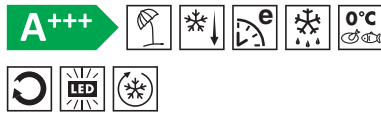

REFRIGERATOR:

Sum of the volumes of the chill compartment(s) and the unfrozen compartment(s): 234 l
 Total No Frost - Double Cooling system
 Fan
 MultiFlow
 Internal light in fridge
 Life Plus zone-0°C
 2 adjustable glass shelves
 Glass shelf to cover fruit and vegetable container
 Type of crisper/vegetable drawers cover: On sliding rails
 Number of fruit and vegetables drawers: 1

INNERDOOR FRIDGE:

Adjustable door shelves with wire support
 Bottle shelves with wire support
 No. of door shelves with transparent cover: 1
 No. of bottle shelves: 1

FREEZER:

Sum of the volumes of the frozen compartment(s): 97 l
 Number of drawers: 3
 Fast freezing compartment
 Type of shelves: Glass

Fast freezing button
 Type of compressor: Inverter

Annual energy consumption: 178 kWh/a
 Electrical connection rating: 127 W
 Climatic class: SN, N, ST, T
 Airborne acoustical noise emissions: 37 dB(A) re 1pW
 Freezing capacity: 6 Kg/24h
 Temperature Rise Time: 40 h

Voltage (V): 220-240 V
 Current: 0.80 A
 Frequency (Hz): 50/60 Hz

Right hand hinges

Right hand hinges

Right hand hinges

Dimensions: 1968x601x728 mm

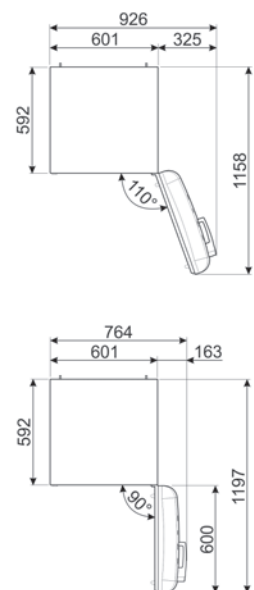
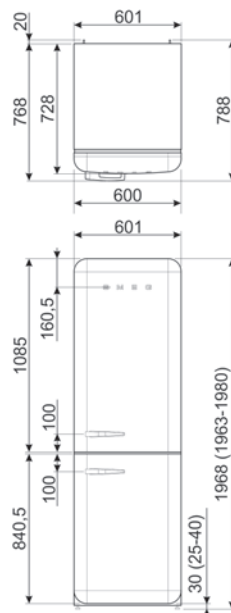

FAB32RSV5

REFRIGERATOR, 50'S STYLE, BOTTOM MOUNT, FREE STANDING, SILVER



FAB32RWH5

REFRIGERATOR, 50'S STYLE, BOTTOM MOUNT, FREE STANDING, WHITE



PLUS:

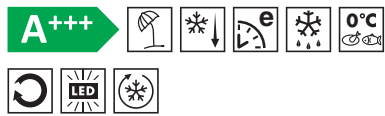

REFRIGERATOR:

Sum of the volumes of the chill compartment(s) and the unfrozen compartment(s): 234 l
 Total No Frost - Double Cooling system Fan
 MultiFlow
 Internal light in fridge
 Life Plus zone 0°C
 2 adjustable glass shelves
 Glass shelf to cover fruit and vegetable container
 Type of crisper/vegetable drawers cover: On sliding rails
 Number of fruit and vegetables drawers: 1

INNERDOOR FRIDGE:

Adjustable door shelves with wire support
 Bottle shelves with wire support
 No. of door shelves with transparent cover: 1
 No. of bottle shelves: 1

FREEZER:

Sum of the volumes of the frozen compartment(s): 97 l
 Number of drawers: 3
 Fast freezing compartment
 Type of shelves: Glass

Fast freezing button
 Type of compressor: Inverter

Annual energy consumption: 178 kWh/a
 Electrical connection rating: 127 W
 Climatic class: SN, N, ST, T
 Airborne acoustical noise emissions: 37 dB(A) re 1pW
 Freezing capacity: 6 Kg/24h
 Temperature Rise Time: 40 h

Voltage (V): 220-240 V
 Current: 0.80 A
 Frequency (Hz): 50/60 Hz

Right hand hinges

Right hand hinges

Dimensions: 1968x601x728 mm

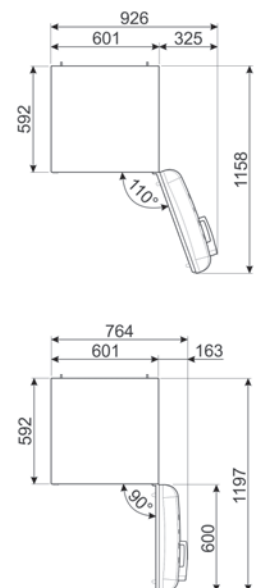
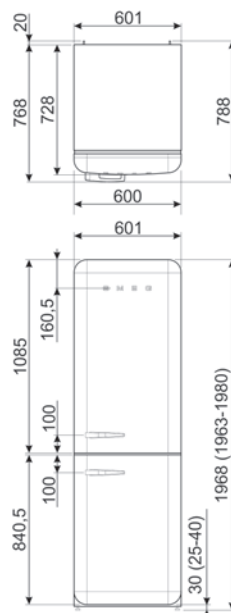



FAB28RDIT5

FAB28RDIT5

REFRIGERATOR, 50'S STYLE, ONE DOOR,
ITALIA FLAG, FREE STANDING



PLUS:



REFRIGERATOR:

Sum of the volumes of the chill compartment(s)
and the unfrozen compartment(s): 244 l

Fan assisted refrigerator, static freezer

Fan

MultiFlow

Internal light in fridge

Life Plus zone-0°C

2 adjustable glass shelves

Glass shelf to cover fruit and vegetable
container

Type of crisper/vegetable drawers cover: On
sliding rails

Number of fruit and vegetables drawers: 1

INNERDOOR FRIDGE:

Adjustable door shelves with wire support

Bottle shelves with wire support

No. of door shelves with transparent cover: 1

No. of bottle shelves: 1

FREEZER:

Sum of the volumes of the frozen
compartment(s): 26 l

Type of compressor: Inverter

Annual energy consumption: 139 kWh/a

Electrical connection rating: 90 W

Climatic class: SN, N, ST, T

Airborne acoustical noise emissions: 35 dB(A)
re 1pW

Freezing capacity: 2 Kg/24h

Temperature Rise Time: 9 h

Voltage (V): 220-240 V

Current: 1 A

Frequency (Hz): 50/60 Hz

Right hand hinges

Dimensions: 1530x601x728 mm

FAB28RDUJ5

REFRIGERATOR, 50'S STYLE, ONE DOOR,
UNION JACK, FREE STANDING



Right hand hinges

FAB28RDMC5

REFRIGERATOR, 50'S STYLE, ONE DOOR,
MULTICOLOR, FREE STANDING



Right hand hinges

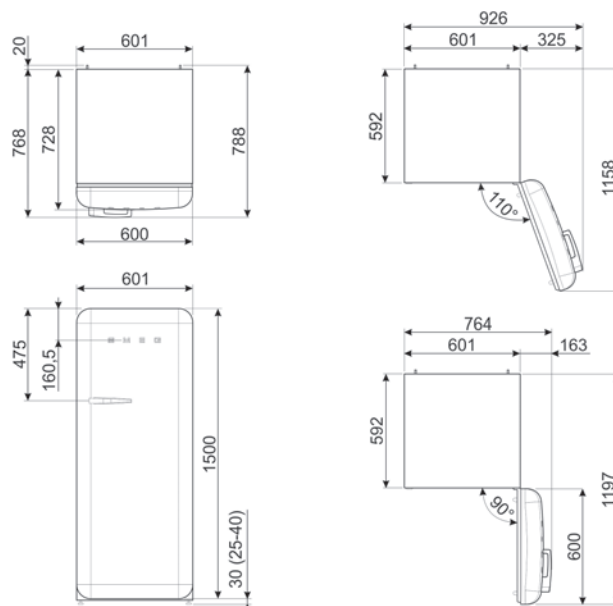

FAB28RDGC5

REFRIGERATOR, 50'S STYLE, ONE DOOR,
SICILIAN CART, FREE STANDING, CREAM



PLUS:



REFRIGERATOR:

Sum of the volumes of the chill compartment(s)
and the unfrozen compartment(s): 244 l

Fan assisted refrigerator, static freezer
Fan

MultiFlow

Internal light in fridge

Life Plus zone 0°C

2 adjustable glass shelves

Glass shelf to cover fruit and vegetable
container

Type of crisper/vegetable drawers cover: On
sliding rails

Number of fruit and vegetables drawers: 1

INNERDOOR FRIDGE:

Adjustable door shelves with wire support

Bottle shelves with wire support

No. of door shelves with transparent cover: 1

No. of bottle shelves: 1

FREEZER:

Sum of the volumes of the frozen
compartment(s): 26 l

Type of compressor: Inverter

Annual energy consumption: 139 kWh/a

Electrical connection rating: 90 W

Climatic class: SN, N, ST, T

Airborne acoustical noise emissions: 35 dB(A)
re 1pW

Freezing capacity: 2 Kg/24h

Temperature Rise Time: 9 h

Voltage (V): 220-240 V

Current: 1 A

Frequency (Hz): 50/60 Hz

Right hand hinges

Dimensions: 1530x601x728 mm

FAB28RDGME5

REFRIGERATOR, 50'S STYLE, ONE DOOR,
MAIOLICA, FREE STANDING, CREAM



Right hand hinges

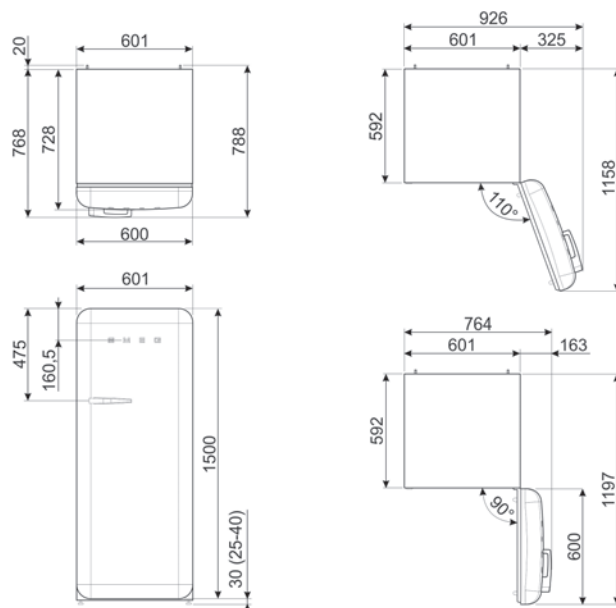

FAB28RDBB5

REFRIGERATOR, 50'S STYLE, ONE DOOR,
LAVAGNA, FREE STANDING



FAB28RDBLV5

REFRIGERATOR, 50'S STYLE, ONE DOOR,
BLACK VELVET, FREE STANDING



FAB28RBL5

REFRIGERATOR, 50'S STYLE, ONE DOOR, FREE
STANDING, BLACK



PLUS:



REFRIGERATOR:

Sum of the volumes of the chill compartment(s)
and the unfrozen compartment(s): 244 l
Fan assisted refrigerator, static freezer
Fan
MultiFlow
Internal light in fridge
Life Plus zone-0°C
2 adjustable glass shelves
Glass shelf to cover fruit and vegetable
container
Type of crisper/vegetable drawers cover: On
sliding rails
Number of fruit and vegetables drawers: 1

INNERDOOR FRIDGE:

Adjustable door shelves with wire support
Bottle shelves with wire support
No. of door shelves with transparent cover: 1
No. of bottle shelves: 1

FREEZER:

Sum of the volumes of the frozen
compartment(s): 26 l
Type of compressor: Inverter

Annual energy consumption: 139 kWh/a
Electrical connection rating: 90 W
Climatic class: SN, N, ST, T
Airborne acoustical noise emissions: 35 dB(A)
re 1pW
Freezing capacity: 2 Kg/24h
Temperature Rise Time: 9 h

Voltage (V): 220-240 V
Current: 1 A
Frequency (Hz): 50/60 Hz

Right hand hinges

Dimensions: 1530x601x728 mm

Right hand hinges

Right hand hinges

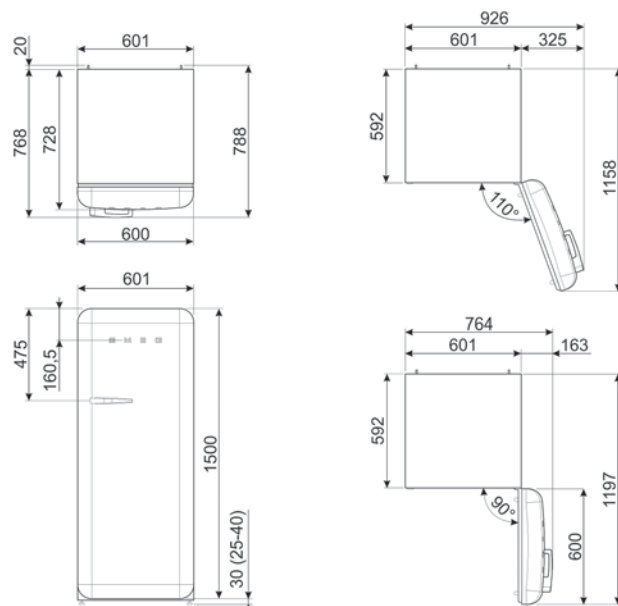

FAB28ROR6

REFRIGERATOR, 50'S STYLE, ONE DOOR, FREE STANDING, ORANGE



FAB28RWH6

REFRIGERATOR, 50'S STYLE, ONE DOOR, FREE STANDING, WHITE



FAB28RLI6

REFRIGERATOR, 50'S STYLE, ONE DOOR, FREE STANDING, LIME GREEN



PLUS:



REFRIGERATOR:

Sum of the volumes of the chill compartment(s) and the unfrozen compartment(s): 244 l
 Fan assisted refrigerator, static freezer
 Fan
 MultiFlow
 Internal light in fridge
 Life Plus zone-0°C
 2 adjustable glass shelves
 Glass shelf to cover fruit and vegetable container
 Type of crisper/vegetable drawers cover: On sliding rails
 Number of fruit and vegetables drawers: 1

INNERDOOR FRIDGE:

Adjustable door shelves with wire support
 Bottle shelves with wire support
 No. of door shelves with transparent cover: 1
 No. of bottle shelves: 1

FREEZER:

Sum of the volumes of the frozen compartment(s): 26 l
 Type of compressor: Inverter

Annual energy consumption: 139 kWh/a
 Electrical connection rating: 90 W
 Climatic class: SN, N, ST, T
 Airborne acoustical noise emissions: 35 dB(A) re 1pW
 Freezing capacity: 2 Kg/24h
 Temperature Rise Time: 9 h

Voltage (V): 220-240 V
 Current: 1 A
 Frequency (Hz): 50/60 Hz

Right hand hinges

Dimensions: 1530x601x728 mm

Right hand hinges

Right hand hinges

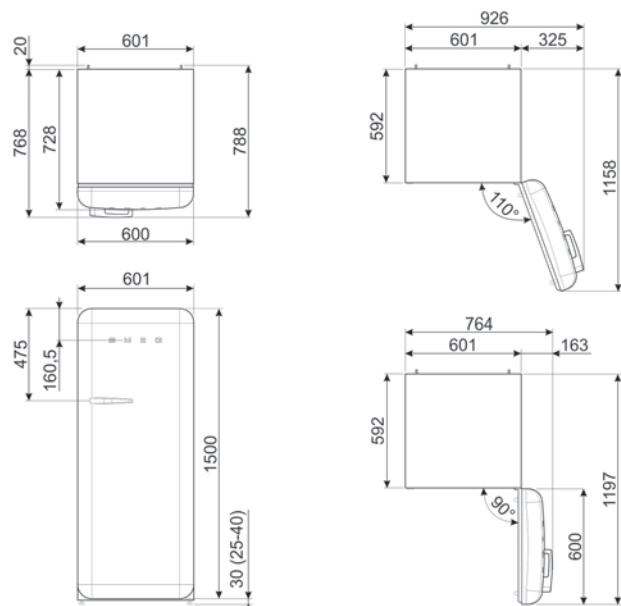

FAB28RRD6

REFRIGERATOR, 50'S STYLE, ONE DOOR, FREE STANDING, RED



FAB28RYW6

REFRIGERATOR, 50'S STYLE, ONE DOOR, FREE STANDING, YELLOW



FAB28RBE6

REFRIGERATOR, 50'S STYLE, ONE DOOR, FREE STANDING, BLUE



PLUS:



REFRIGERATOR:

Sum of the volumes of the chill compartment(s) and the unfrozen compartment(s): 244 l

Fan assisted refrigerator, static freezer

Fan

MultiFlow

Internal light in fridge

Life Plus zone-0°C

2 adjustable glass shelves

Glass shelf to cover fruit and vegetable container

Type of crisper/vegetable drawers cover: On sliding rails

Number of fruit and vegetables drawers: 1

INNERDOOR FRIDGE:

Adjustable door shelves with wire support

Bottle shelves with wire support

No. of door shelves with transparent cover: 1

No. of bottle shelves: 1

FREEZER:

Sum of the volumes of the frozen compartment(s): 26 l

Type of compressor: Inverter

Annual energy consumption: 139 kWh/a

Electrical connection rating: 90 W

Climatic class: SN, N, ST, T

Airborne acoustical noise emissions: 35 dB(A) re 1pW

Freezing capacity: 2 Kg/24h

Temperature Rise Time: 9 h

Voltage (V): 220-240 V

Current: 1 A

Frequency (Hz): 50/60 Hz

Right hand hinges

Dimensions: 1530x601x728 mm

Right hand hinges

Right hand hinges

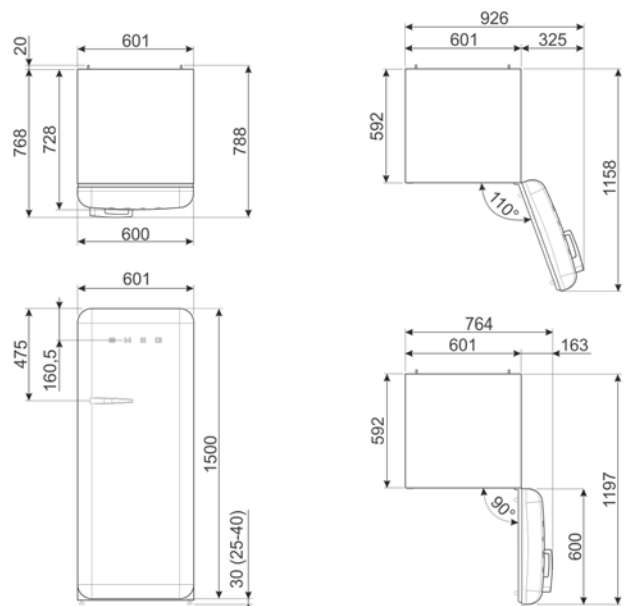

FAB28RPB6

REFRIGERATOR, 50'S STYLE, ONE DOOR, FREE STANDING, PASTEL BLUE



FAB28RPG6

REFRIGERATOR, 50'S STYLE, ONE DOOR, FREE STANDING, PASTEL GREEN



FAB28RPK6

REFRIGERATOR, 50'S STYLE, ONE DOOR, FREE STANDING, PINK



PLUS:



REFRIGERATOR:

Sum of the volumes of the chill compartment(s) and the unfrozen compartment(s): 244 l

Fan assisted refrigerator, static freezer

Fan

MultiFlow

Internal light in fridge

Life Plus zone-0°C

1 adjustable glass shelf

Glass shelf to cover fruit and vegetable container

Type of crisper/vegetable drawers cover: On sliding rails

Number of fruit and vegetables drawers: 1

INNERDOOR FRIDGE:

Adjustable door shelves with wire support

Bottle shelves with wire support

No. of door shelves with transparent cover: 1

No. of bottle shelves: 1

FREEZER:

Sum of the volumes of the frozen compartment(s): 26 l

Type of compressor: Inverter

Annual energy consumption: 139 kWh/a

Electrical connection rating: 90 W

Climatic class: SN, N, ST, T

Airborne acoustical noise emissions: 35 dB(A) re 1pW

Freezing capacity: 2 Kg/24h

Temperature Rise Time: 9 h

Voltage (V): 220-240 V

Current: 1 A

Frequency (Hz): 50/60 Hz

Right hand hinges

Dimensions: 1530x601x728 mm

Right hand hinges

Right hand hinges

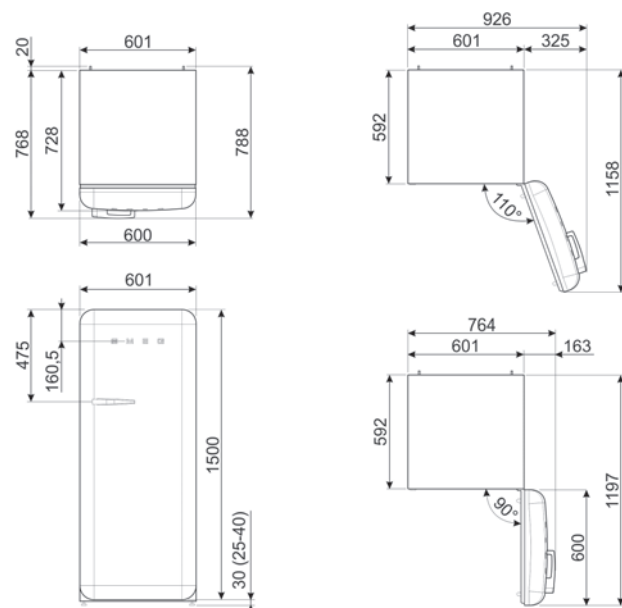

FAB28RCR6

REFRIGERATOR, 50'S STYLE, ONE DOOR, FREE STANDING, CREAM



FAB28RSV6

REFRIGERATOR, 50'S STYLE, ONE DOOR, FREE STANDING, SILVER



PLUS:



REFRIGERATOR:

Sum of the volumes of the chill compartment(s) and the unfrozen compartment(s): 244 l

Fan assisted refrigerator, static freezer

Fan

MultiFlow

Internal light in fridge

Life Plus zone 0°C

2 adjustable glass shelves

Glass shelf to cover fruit and vegetable container

Type of crisper/vegetable drawers cover: On sliding rails

Number of fruit and vegetables drawers: 1

Number of fruit and vegetables drawers: 1

Number of fruit and vegetables drawers: 1

Number of fruit and vegetables drawers: 1

INNERDOOR FRIDGE:

Adjustable door shelves with wire support

Bottle shelves with wire support

No. of door shelves with transparent cover: 1

No. of bottle shelves: 1

FREEZER:

Sum of the volumes of the frozen compartment(s): 26 l

Sum of the volumes of the frozen compartment(s): 26 l

Type of compressor: Inverter

Annual energy consumption: 139 kWh/a

Electrical connection rating: 90 W

Climatic class: SN, N, ST, T

Airborne acoustical noise emissions: 35 dB(A)

re 1pW

Freezing capacity: 2 Kg/24h

Temperature Rise Time: 9 h

Voltage (V): 220-240 V

Current: 1 A

Frequency (Hz): 50/60 Hz

Right hand hinges

Dimensions: 1530x601x728 mm

Right hand hinges

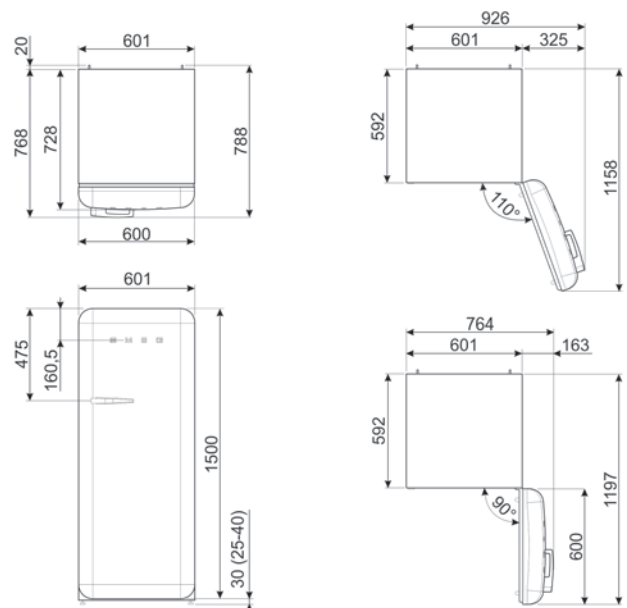



FAB10HRRD6

FAB10HRDIT6

REFRIGERATOR, 50'S STYLE, ONE DOOR,
ITALIA FLAG, FREE STANDING



FAB10HRRD6

REFRIGERATOR, 50'S STYLE, ONE DOOR,
FREE STANDING, RED



FAB10HRCR6

REFRIGERATOR, 50'S STYLE, ONE DOOR, FREE
STANDING, CREAM



PLUS:



Right hand hinges

Right hand hinges

REFRIGERATOR:

Sum of the volumes of the chill compartment(s)
and the unfrozen compartment(s): 135 l

Static

Internal light in fridge

2 adjustable glass shelves

INNERDOOR FRIDGE:

No. of bottle shelves: 1

Type of compressor: Standard

Annual energy consumption: 88 kWh/a

Climatic class: SN, N, ST, T

Airborne acoustical noise emissions: 35 dB(A)
re 1pW

Voltage (V): 220-240 V

Current: 0.35 A

Frequency (Hz): 50 Hz

Right hand hinges

Dimensions: 970x545x659 mm

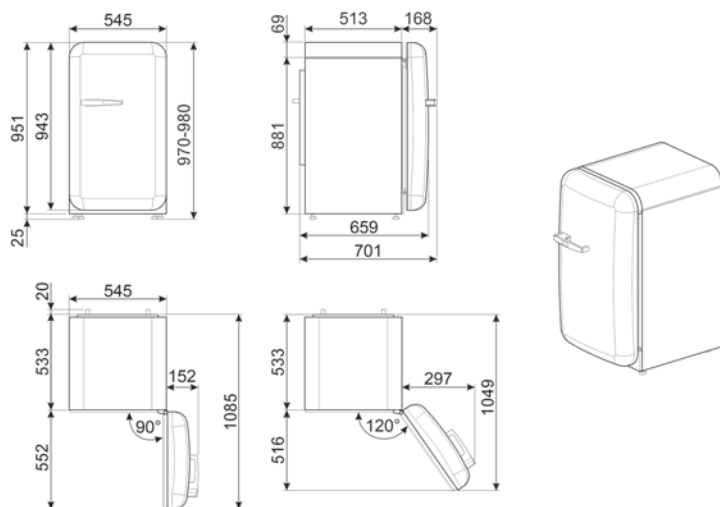

FAB10HRPB6

REFRIGERATOR, 50'S STYLE, ONE DOOR, FREE STANDING, PASTEL BLUE



FAB10HRPG6

REFRIGERATOR, 50'S STYLE, ONE DOOR, FREE STANDING, PASTEL GREEN



FAB10HRPK6

REFRIGERATOR, 50'S STYLE, ONE DOOR, FREE STANDING, PINK



PLUS:



Right hand hinges

Right hand hinges

REFRIGERATOR:

Sum of the volumes of the chill compartment(s) and the unfrozen compartment(s): 135 l

Static

Internal light in fridge

2 adjustable glass shelves

INNERDOOR FRIDGE:

No. of bottle shelves: 1

Type of compressor: Standard

Annual energy consumption: 88 kWh/a

Climatic class: SN, N, ST, T

Airborne acoustical noise emissions: 35 dB(A) re 1pW

Voltage (V): 220-240 V

Current: 0.35 A

Frequency (Hz): 50 Hz

Right hand hinges

Dimensions: 970x545x659 mm

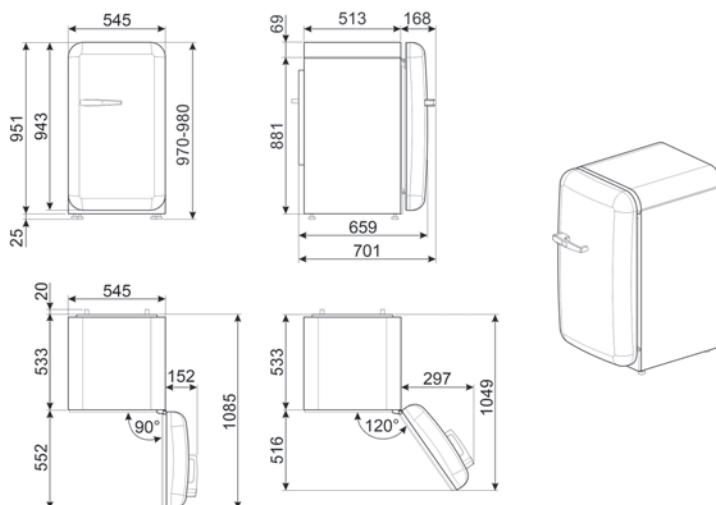



FAB10RCR6

FAB10RDUJ6

REFRIGERATOR, 50'S STYLE, ONE DOOR,
UNION JACK, FREE STANDING



PLUS:



FAB10ROR6

REFRIGERATOR, 50'S STYLE, ONE DOOR,
FREE STANDING, ORANGE



Right hand hinges

FAB10RRD6

REFRIGERATOR, 50'S STYLE, ONE DOOR, FREE
STANDING, RED



Right hand hinges

REFRIGERATOR:

Sum of the volumes of the chill compartment(s)
and the unfrozen compartment(s): 105 l
Static

Internal light in fridge

1 adjustable glass shelf

Glass shelf to cover fruit and vegetable
container

Type of crisper/vegetable drawers cover:
Standard

Number of fruit and vegetables drawers: 1

INNERDOOR FRIDGE:

No. of bottle shelves: 1

FREEZER:

Sum of the volumes of the frozen
compartment(s): 17 l

Type of compressor: Standard

Annual energy consumption: 142 kWh/a

Climatic class: SN, N, ST, T

Airborne acoustical noise emissions: 37 dB(A)
re 1pW

Freezing capacity: 2.58 Kg/24h

Temperature Rise Time: 9 h

Voltage (V): 220-240 V

Current: 0.42 A

Frequency (Hz): 50 Hz

Right hand hinges

Dimensions: 970x545x659 mm

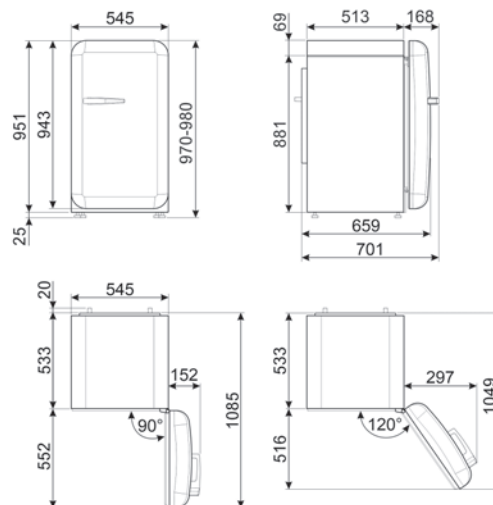

FAB10RPB6

REFRIGERATOR, 50'S STYLE, ONE DOOR, FREE STANDING, PASTEL BLUE



FAB10RPG6

REFRIGERATOR, 50'S STYLE, ONE DOOR, FREE STANDING, PASTEL GREEN



FAB10RPK6

REFRIGERATOR, 50'S STYLE, ONE DOOR, FREE STANDING, PINK



PLUS:



Right hand hinges

Right hand hinges

REFRIGERATOR:

Sum of the volumes of the chill compartment(s) and the unfrozen compartment(s): 105 l
Static

Internal light in fridge
1 adjustable glass shelf

Glass shelf to cover fruit and vegetable container

Type of crisper/vegetable drawers cover:
Standard

Number of fruit and vegetables drawers: 1

INNERDOOR FRIDGE:

No. of bottle shelves: 1

FREEZER:

Sum of the volumes of the frozen compartment(s): 17 l

Type of compressor: Standard

Annual energy consumption: 142 kWh/a

Climatic class: SN, N, ST, T

Airborne acoustical noise emissions: 37 dB(A)
re 1pW

Freezing capacity: 2.58 Kg/24h

Temperature Rise Time: 9 h

Voltage (V): 220-240 V

Current: 0.42 A

Frequency (Hz): 50 Hz

Right hand hinges

Dimensions: 970x545x659 mm

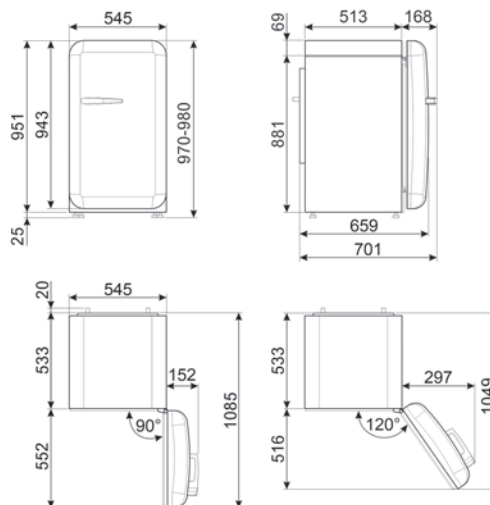

FAB10RCR6

REFRIGERATOR, 50'S STYLE, ONE DOOR, FREE
STANDING, CREAM



PLUS:



REFRIGERATOR:

Sum of the volumes of the chill compartment(s)
and the unfrozen compartment(s): 105 l

Static

Internal light in fridge

1 adjustable glass shelf

Glass shelf to cover fruit and vegetable
container

Type of crisper/vegetable drawers cover:

Standard

Number of fruit and vegetables drawers: 1

INNERDOOR FRIDGE:

No. of bottle shelves: 1

FREEZER:

Sum of the volumes of the frozen
compartment(s): 17 l

Type of compressor: Standard

Annual energy consumption: 142 kWh/a

Climatic class: SN, N, ST, T

Airborne acoustical noise emissions: 37 dB(A)
re 1pW

Freezing capacity: 2.58 Kg/24h

Temperature Rise Time: 9 h

Voltage (V): 220-240 V

Current: 0.42 A

Frequency (Hz): 50 Hz

Right hand hinges

Dimensions: 970x545x659 mm

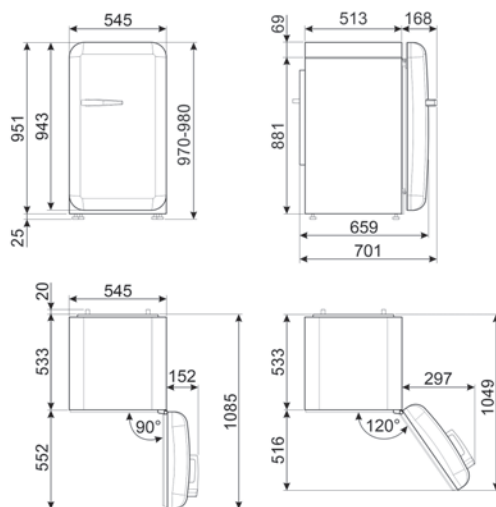



FAB5RDUJ

FAB5RDUJ5

REFRIGERATOR, 50'S STYLE, ONE DOOR,
UNION JACK, FREE STANDING



PLUS:



REFRIGERATOR:

Sum of the volumes of the chill compartment(s)
and the unfrozen compartment(s): 34 l

Static

Internal light in fridge

2 adjustable glass shelves

INNERDOOR FRIDGE:

Adjustable door shelves with wire support

Bottle shelves with wire support

No. of bottle shelves: 1

Type of compressor: Standard

Annual energy consumption: 54 kWh/a

Electrical connection rating: 60 W

Climatic class: SN, N, ST, T

Airborne acoustical noise emissions: 40 dB(A)
re 1pW

Voltage (V): 220-240 V

Current: 0.22 A

Frequency (Hz): 50/60 Hz

Right hand hinges

Dimensions: 725x404x500 mm

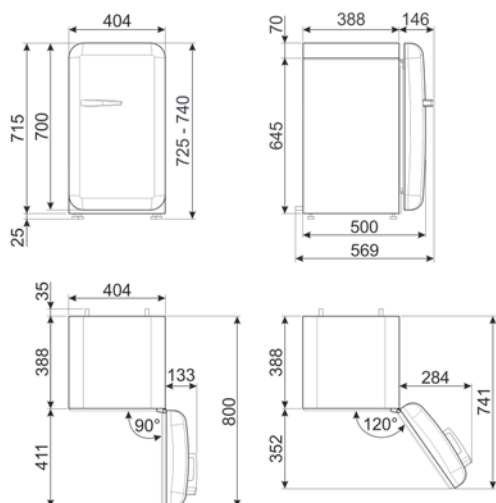

FAB5RRD5

REFRIGERATOR, 50'S STYLE, ONE DOOR, FREE STANDING, RED



FAB5ROR5

REFRIGERATOR, 50'S STYLE, ONE DOOR, FREE STANDING, ORANGE



PLUS:



Right hand hinges

REFRIGERATOR:

Sum of the volumes of the chill compartment(s) and the unfrozen compartment(s): 34 l

Static

Internal light in fridge

2 adjustable glass shelves

INNERDOOR FRIDGE:

Adjustable door shelves with wire support

Bottle shelves with wire support

No. of bottle shelves: 1

Type of compressor: Standard

Annual energy consumption: 54 kWh/a

Electrical connection rating: 60 W

Climatic class: SN, N, ST, T

Airborne acoustical noise emissions: 40 dB(A)
re 1pW

Voltage (V): 220-240 V

Current: 0.22 A

Frequency (Hz): 50/60 Hz

Right hand hinges

Dimensions: 725x404x500 mm

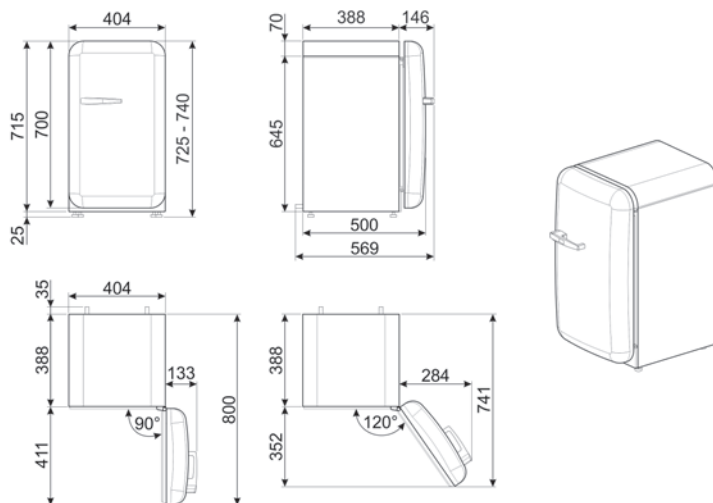

FAB5RPB5

REFRIGERATOR, 50'S STYLE, ONE DOOR, FREE STANDING, PASTEL BLUE



FAB5RPG5

REFRIGERATOR, 50'S STYLE, ONE DOOR, FREE STANDING, PASTEL GREEN



FAB5RPK5

REFRIGERATOR, 50'S STYLE, ONE DOOR, FREE STANDING, PINK



PLUS:



Right hand hinges

Right hand hinges

REFRIGERATOR:

Sum of the volumes of the chill compartment(s) and the unfrozen compartment(s): 34 l

Static

Internal light in fridge

2 adjustable glass shelves

INNERDOOR FRIDGE:

Adjustable door shelves with wire support

Bottle shelves with wire support

No. of bottle shelves: 1

Type of compressor: Standard

Annual energy consumption: 54 kWh/a

Electrical connection rating: 60 W

Climatic class: SN, N, ST, T

Airborne acoustical noise emissions: 40 dB(A) re 1pW

Voltage (V): 220-240 V

Current: 0.22 A

Frequency (Hz): 50/60 Hz

Right hand hinges

Dimensions: 725x404x500 mm

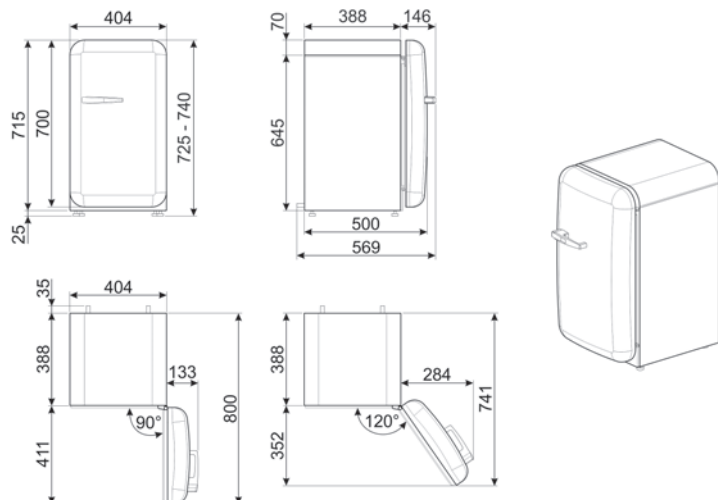

FAB5RCR5

REFRIGERATOR, 50'S STYLE, ONE DOOR, FREE STANDING, CREAM



FAB5RSV5

REFRIGERATOR, 50'S STYLE, ONE DOOR, FREE STANDING, SILVER



PLUS:



Right hand hinges

REFRIGERATOR:

Sum of the volumes of the chill compartment(s) and the unfrozen compartment(s): 34 l

Static

Internal light in fridge

2 adjustable glass shelves

INNERDOOR FRIDGE:

Adjustable door shelves with wire support

Bottle shelves with wire support

No. of bottle shelves: 1

Type of compressor: Standard

Annual energy consumption: 54 kWh/a

Electrical connection rating: 60 W

Climatic class: SN, N, ST, T

Airborne acoustical noise emissions: 40 dB(A) re 1pW

Voltage (V): 220-240 V

Current: 0.22 A

Frequency (Hz): 50/60 Hz

Right hand hinges

Dimensions: 725x404x500 mm

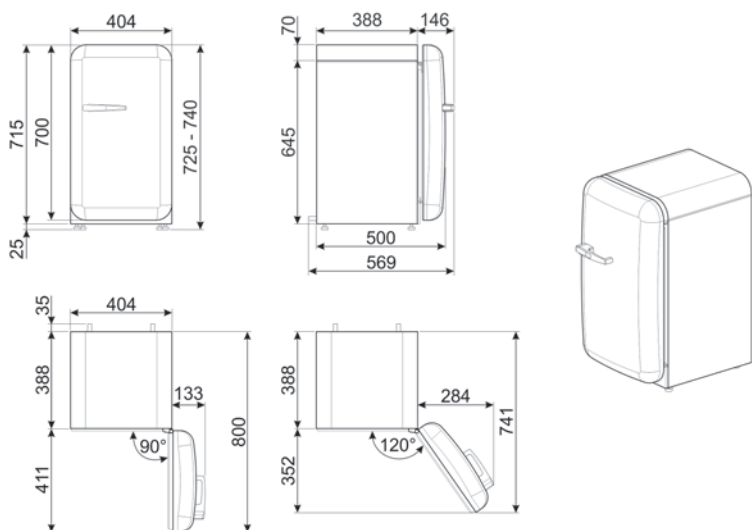



SMEG500B

SMEG500B



SMEG500G



SMEG500BL



SMEG500R



SMEG500V







SMALL DOMESTIC APPLIANCES

The latest addition to the Smeg 50's style family is a fabulous collection of small domestic appliances to put the finishing touches of colour and design into the kitchen. These curved and compact products recollect the past and are reminiscence of 1950's retro style while offering the most update technologies.

KLF03DGEU

KETTLES, 50'S STYLE, SICILY IS MY LOVE,
FINISHING: GLOSSY



2400 W
Lid opening
360° swivel base
Water level indicator
Max capacity: 1.7lt / 7 cups
Auto switch off: Yes, at 100°C
Safety auto shut off

Body material: Stainless steel
Filter material: Stainless steel
Spout material: Stainless steel
Built-in cord wrap
Antislip feet

Dimensions of the product HxVxD (mm):
248x226x171 mm

TSF01DGEU

TOASTER 2X2, 50'S STYLE, SICILY IS MY
LOVE, FINISHING: GLOSSY



950 W
No. of toasting levels: 6
No. of slices: 2
No. of slots: 2
Slot width: 36 mm
Automatic pop-up

Reheat function
Defrost function
Bagel function

Body material: Stainless steel
Lever material: Stainless steel
Crumb tray material: Polished steel
Buttons material: Plastic
Anti-slip feet
Integrated cord

Product dimensions: 198 x 310 (325 with
ball lever included) x 195 mm

SMF03DGEU

STAND MIXER, 50'S STYLE, SICILY IS MY
LOVE, FINISHING: GLOSSY



800 W
Direct drive
Speeds: 10
Smooth start function
Action: Planetary
Accessory port for optionals: Frontal
Safety lock when the head is tilted up

Max egg whites: 12
Min. egg whites: 3
Max pre-prepared cake batters: 2.0 Kg
Bread/pizza dough: 1.8 kg total dough
(max 1.2 kg flour)
Whipped cream max: 1 l

Body material: Die-cast aluminium
Base material: Alluminio pressofuso
Lever material: Stainless steel
Anti-slip feet

Product dimensions: 378 (490 with head up)
x 402 x 221 mm

ACCESSORIES INCLUDED:

Dough hook
Wire whisk
Flat beater
Bowl
Pouring shield

Flat beater dishwasher safe



KLF03DGBEU

KETTLES, 50'S STYLE, BLU MEDITERRANEO,
FINISHING: GLOSSY



2400 W
Lid opening
360° swivel base
Water level indicator
Max capacity: 1.7lt / 7 cups
Auto switch off: Yes, at 100°C
Safety auto shut off

Body material: Stainless steel
Filter material: Stainless steel
Spout material: Stainless steel
Built-in cord wrap
Antislip feet

Dimensions of the product HxVxD (mm):
248x226x171 mm

TSF01DGBEU

TOASTER 2X2, 50'S STYLE, BLU MEDITERRANEO,
FINISHING: GLOSSY



950 W
No. of toasting levels: 6
No. of slices: 2
No. of slots: 2
Slot width: 36 mm
Automatic pop-up

Reheat function
Defrost function
Bagel function

Body material: Stainless steel
Lever material: Stainless steel
Crumb tray material: Polished steel
Buttons material: Plastic
Anti-slip feet
Integrated cord

Product dimensions: 198 x 310 (325 with
ball lever included) x 195 mm

ECF02DGBEU

ESPRESSO COFFEE MACHINE, 50'S STYLE,
BLU MEDITERRANEO, FINISHING: GLOSSY



1350 W
Heating System: Thermoblock
Pump Pressure: 15 bar
Water Container Capacity: 1 l
Removable Water Container
Passive
Removable Drip Tray
Paper Pods Filter
Decalcification alarm
Buttons, Lever
Hot Water Function
Adjustable Stand-by Function
Adjustable Coffee Temperature: low/
medium/high
Adjustable coffee length
Adjustable water hardness
Stand-by setting: 9 min/30 min/3 hrs

Stainless Steel/Plastic
Cup Warmer Material: Stainless steel
Drip Tray Material: Plastic
Antislip Base

Product Dimensions: HxLxP
330x149x329 mm

ACCESSORIES INCLUDED:

Double Wall 1 Cup Filter
Double wall 2 Cups Filter
Paper Pods Filter
Measurer/Tamper

CGF11DGBEU

COFFEE GRINDER, 50'S STYLE,
BLU MEDITERRANEO, FINISHING: GLOSSY



150 W
RPM: 450
Burr type: conical
Antistatic system
Coffee bean container capacity: 350 gr
Ground coffee container capacity: 130 g
Ground coffee container with Twist & Lock system

Adjustable grinding size
Available grinding steps: FINE , MEDIUM ,
COARSE
Manual function

Body material: Stainless Steel
Coffee bean container material: BPA-free plastic
Ground coffee container material: BPA-free plastic
Container support plate material: Steel
Antislip base
Built-in cord wrap

Product Dimensions W x H x D: 220 x
385 x 150 mm

ACCESSORIES INCLUDED:

Centering filter support
Powder container support
Cleaning brush

MFF11DGBEU

MILK FROTHER, 50'S STYLE,
BLU MEDITERRANEO, FINISHING: GLOSSY



500 W
Milk and Chocolate heating Jug capacity:
600 ml / 2.5 cup
Milk frothing Jug capacity: 250 ml / 1 cup
Removable Carafe
Removable measuring cup/lid
Button , Knob
Induction system with automatic switch off

Cold Froth Dense function
Cold Froth Light function
Hot Froth Dense function
Hot Froth Light function
Hot Milk function
Hot Chocolate function
Manual Cold function
Manual Hot function

Body material: Stainless steel
Carafe material: Stainless steel
Lid material: Tritan™ Renew
Antislip Base: Yes
Integrated cord wrap

Product Dimensions W x H x D: HxLxP 251 x
184 x 142 mm

ACCESSORIES INCLUDED:

Smooth Disc for Hot Milk and Manual
functions
Notched Disc for Froth and Manual functions

CJF11DGBEU

CITRUS JUICER, 50'S STYLE,
BLU MEDITERRANEO, FINISHING: GLOSSY



70 W
Juicing System: Manual Pressure
Universal Cone
Cone Rotation: 1 way - anticlockwise
Tension: 220-240 V

Body Material: Die-cast Aluminum
Cone Material: Stainless steel
Spout Material: Stainless steel
Lid Material: Plastic
Anti-slip base
Built-in cord wrap

Product Dimensions (HxLxW):
281x166x166 mm

KLF03SBMEU

KETTLES, 50'S STYLE, STROM BLUE



2400 W
Lid opening
360° swivel base
Water level indicator
Max capacity: 1.7lt / 7 cups
Auto switch off: Yes, at 100°C
Safety auto shut off

Body material: Stainless steel
Filter material: Stainless steel
Spout material: Stainless steel
Built-in cord wrap
Antislip feet

Dimensions of the product HxWxD (mm):
248x226x171 mm

TSF01SBMEU

TOASTER 2X2, 50'S STYLE, STROM BLUE



950 W
No. of toasting levels: 6
No. of slices: 2
No. of slots: 2
Slot width: 36 mm
Automatic pop-up

Reheat function
Defrost function
Bagel function

Body material: Stainless steel
Lever material: Stainless steel
Crumb tray material: Polished steel
Buttons material: Plastic
Anti-slip feet
Integrated cord

Product dimensions: 198 x 310 (325 with
ball lever included) x 195 mm

KLF03EGMEU

KETTLES, 50'S STYLE, EMERALD GREEN



2400 W
Lid opening
360° swivel base
Water level indicator
Max capacity: 1.7lt / 7 cups
Auto switch off: Yes, at 100°C
Safety auto shut off

Body material: Stainless steel
Filter material: Stainless steel
Spout material: Stainless steel
Built-in cord wrap
Antislip feet

Dimensions of the product HxWxD (mm):
248x226x171 mm

TSF01EGMEU

TOASTER 2X2, 50'S STYLE, EMERALD GREEN



950 W
No. of toasting levels: 6
No. of slices: 2
No. of slots: 2
Slot width: 36 mm
Automatic pop-up

Reheat function
Defrost function
Bagel function

Body material: Stainless steel
Lever material: Stainless steel
Crumb tray material: Polished steel
Buttons material: Plastic
Anti-slip feet
Integrated cord

Product dimensions: 198 x 310 (325 with
ball lever included) x 195 mm

KLF03WHMEU

KETTLES, 50'S STYLE, WHITE,
FINISHING: MATT



2400 W
Lid opening
360° swivel base
Water level indicator
Max capacity: 1.7lt / 7 cups
Auto switch off: Yes, at 100°C
Safety auto shut off

Body material: Stainless steel
Filter material: Stainless steel
Spout material: Stainless steel
Built-in cord wrap
Antislip feet

Dimensions of the product HxWxD (mm):
248x226x171 mm

TSF01WHMEU

TOASTER 2X2, 50'S STYLE, WHITE,
FINISHING: MATT



950 W
No. of toasting levels: 6
No. of slices: 2
No. of slots: 2
Slot width: 36 mm
Automatic pop-up

Reheat function
Defrost function
Bagel function

Body material: Stainless steel
Lever material: Stainless steel
Crumb tray material: Polished steel
Buttons material: Plastic
Anti-slip feet
Integrated cord

Product dimensions: 198 x 310 (325 with
ball lever included) x 195 mm

KBSF02BL

KNIFE BLOCK, 50'S STYLE, BLACK,
FINISHING: GLOSSY



KBSF02CR

KNIFE BLOCK, 50'S STYLE, CREAM,
FINISHING: GLOSSY



KBSF02PB

KNIFE BLOCK, 50'S STYLE, PASTEL BLUE,
FINISHING: GLOSSY



50's Style

Body Material : Stainless Steel

Base Finishing : Glossy Chromed

Knives slots : Acacia Wood

Knives Material : German Stainless Steel

6 Exclusive Knives : Utility Knife, Meat Knife

Santoku Knife, Bread Knife, Chef's Knife

Type of logo : Applied

SMF02BLEU

STAND MIXER, 50'S STYLE, BLACK,
FINISHING: GLOSSY



SMF02CREU

STAND MIXER, 50'S STYLE, CREAM,
FINISHING: GLOSSY



SMF02PBEU

STAND MIXER, 50'S STYLE, PASTEL BLUE,
FINISHING: GLOSSY



800 W
Direct drive
Speeds: 10
Smooth start function
Action: Planetarium
Accessory port for optionals: Frontal
Safety lock when the head is tilted up

Max egg whites: 12
Min. egg whites: 2
Max pre-prepared cake batters: 2.0 Kg
Bread/pizza dough: 1.8 kg total dough
(max 1.2 kg flour)
Whipped cream max: 1 l

Body material: Die-cast aluminium
Base material: Alluminio pressofuso
Lever material: Stainless steel
Anti-slip feet

Product dimensions: 378 (490 with head up)
x 402 x 221 mm

ACCESSORIES INCLUDED:

Dough hook
Wire whisk
Flat beater
Bowl
Pouring shield

Flat beater dishwasher safe

SMF02RDEU

STAND MIXER, 50'S STYLE, RED,
FINISHING: GLOSSY



SMF02SVEU

STAND MIXER, 50'S STYLE, SILVER,
FINISHING: GLOSSY



SMF02WHEU

STAND MIXER, 50'S STYLE, WHITE,
FINISHING: GLOSSY



HMFO1BLEU

HAND MIXER, 50'S STYLE, BLACK,
FINISHING: GLOSSY



Power: 250 W
Speeds: 9
Turbo Function
Smooth start system
LED hidden display
Minutes count up timer
Seconds count up timer

ACCESSORIES INCLUDED:

Dough hook: 2
Dough hook material: Stainless steel
Optimus beater: 2
Optimus beater material: Stainless steel
Wire whisk: 2
Accessory bag

HMFO1CREU

HAND MIXER, 50'S STYLE, CREAM,
FINISHING: GLOSSY



HMFO1PBEU

HAND MIXER, 50'S STYLE, PASTEL BLUE,
FINISHING: GLOSSY



HMFO1PGEU

HAND MIXER, 50'S STYLE, PASTEL GREEN,
FINISHING: GLOSSY



HMFO1PKEU

HAND MIXER, 50'S STYLE, PINK,
FINISHING: GLOSSY



HMFO1RDEU

HAND MIXER, 50'S STYLE, RED,
FINISHING: GLOSSY



HMFO1WHEU

HAND MIXER, 50'S STYLE, WHITE,
FINISHING: GLOSSY



COF01BLEU

COMBI STEAM OVEN, 50'S STYLE, BLACK,
FINISHING: GLOSSY



COF01CREU

COMBI STEAM OVEN, 50'S STYLE, CREAM,
FINISHING: GLOSSY



COF01PBEU

COMBI STEAM OVEN, 50'S STYLE, PASTEL BLUE,
FINISHING: GLOSSY



Capacity: 30L
3 Cooking Levels
Multifunction cooking
Steam Menu Function with Pure Steam
LCD display
Air Fry, Warm, Defrost
Chef Menu with 33 recipes
.8L removable water tank
Descaling alarm, child lock

ACCESSORIES INCLUDED:

Grill tray
Baking tray
Perforated tray

Product dimensions: HxVxD
400x500x510 mm

COF01PGEU

COMBI STEAM OVEN, 50'S STYLE,
PASTEL GREEN, FINISHING: GLOSSY



COF01WHEU

COMBI STEAM OVEN, 50'S STYLE, WHITE,
FINISHING: GLOSSY



BLF03BLEU

BLENDERS, 50'S STYLE, BLACK, NA,
FINISHING: GLOSSY



800 W
Buttons, control knobs
Motor with Smooth Start function
Detachable blade assembly
Detachable blade material: Stainless steel
Jug capacity: 1.5lt / 6 cups
Measuring cup/lid: Yes
Motor thermal protection
Safety motor block

Pulse function
Smoothie function
Ice crush function

Body material: Cast aluminium
Jug material: BPA-free plastic
Antislip base
Built-in cord wrap

Product dimensions: HxWxD
397x197x163 mm

BLF03CREU

BLENDERS, 50'S STYLE, CREAM, NA,
FINISHING: GLOSSY



BLF03PBEU

BLENDERS, 50'S STYLE, PASTEL BLUE, NA,
FINISHING: GLOSSY



BLF03PGEU

BLENDERS, 50'S STYLE, PASTEL GREEN, NA,
FINISHING: GLOSSY



BLF03PKEU

BLENDERS, 50'S STYLE, PINK, NA,
FINISHING: GLOSSY



BLF03WHEU

BLENDERS, 50'S STYLE, WHITE, NA,
FINISHING: GLOSSY



BLF03RDEU

BLENDERS, 50'S STYLE, RED, NA,
FINISHING: GLOSSY



CJF11BLEU

CITRUS JUICER, 50'S STYLE, BLACK,
FINISHING: GLOSSY



70 W
Juicing System: Manual Pressure
Universal Cone
Cone Rotation: 1 way - anticlockwise
Tension: 220-240 V

Body Material: Die-cast Aluminum
Cone Material: Stainless steel
Spout Material: Stainless steel
Lid Material: Plastic
Anti-slip base
Built-in cord wrap

Product Dimensions (HxLxW):
281x166x166 mm

CJF11CREU

CITRUS JUICER, 50'S STYLE, CREAM,
FINISHING: GLOSSY



CJF11PBEU

CITRUS JUICER, 50'S STYLE, PASTEL BLUE,
FINISHING: GLOSSY



CJF11PGEU

CITRUS JUICER, 50'S STYLE, PASTEL GREEN,
FINISHING: GLOSSY



CJF11PKEU

CITRUS JUICER, 50'S STYLE, PINK,
FINISHING: GLOSSY



CJF11RDEU

CITRUS JUICER, 50'S STYLE, RED,
FINISHING: GLOSSY



CJF11WHEU

CITRUS JUICER, 50'S STYLE, WHITE,
FINISHING: GLOSSY



KLF03BLEU

KETTLES, 50'S STYLE, BLACK, FINISHING:
GLOSSY



2400 W
Lid opening
360° swivel base
Water level indicator
Max capacity: 1.7lt / 7 cups
Auto switch off: Yes, at 100°C
Safety auto shut off

Body material: Stainless steel
Filter material: Stainless steel
Spout material: Stainless steel
Built-in cord wrap
Antislip feet

Dimensions of the product HxWxD (mm):
248x226x171 mm

KLF03CREU

KETTLES, 50'S STYLE, CREAM, FINISHING:
GLOSSY



KLF03PBEU

KETTLES, 50'S STYLE, PASTEL BLUE,
FINISHING: GLOSSY



KLF03PGEU

KETTLES, 50'S STYLE, PASTEL GREEN,
FINISHING: GLOSSY



KLF03RDEU

KETTLES, 50'S STYLE, RED, FINISHING:
GLOSSY



KLF03PKEU

KETTLES, 50'S STYLE, PINK, FINISHING:
GLOSSY



KLF04BLEU

KETTLES, 50'S STYLE, BLACK, FINISHING: GLOSSY



2400 W
Temperature settings: 50°C; 60°C; 70° C;
80° C; 90°C; 95°C; 100°C
Keep warm
Lid opening
360° swivel base
Water level indicator
Max capacity: 1.7lt / 7 cups
Auto switch off: Yes, when at selected
temperature
Safety auto shut off

Body material: Stainless steel
Filter material: Stainless steel
Spout material: Stainless steel
Button material: Plastic
Built-in cord wrap
Antislip feet

Dimensions of the product HxVxD (mm):
275x226x171 mm

KLF04CREU

KETTLES, 50'S STYLE, CREAM, FINISHING: GLOSSY



KLF04PGEU

KETTLES, 50'S STYLE, PASTEL GREEN, FINISHING: GLOSSY



KLF04PBEU

KETTLES, 50'S STYLE, PASTEL BLUE, FINISHING: GLOSSY



KLF04PKEU

KETTLES, 50'S STYLE, PINK, FINISHING: GLOSSY



KLF04RDEU

KETTLES, 50'S STYLE, RED, FINISHING: GLOSSY



KLF04WHEU

KETTLES, 50'S STYLE, WHITE, FINISHING: GLOSSY



KLF05BLEU

KETTLES, 50'S STYLE, BLACK, FINISHING: GLOSSY



1400 W
Lid opening
360° swivel base
Water level indicator
Max capacity: 0.8 lt /3 cups
Auto switch off: Yes, at 100°C
Safety auto shut off

Body material: Plastic
Filter material: Stainless steel
Spout material: Stainless steel
Built-in cord wrap
Antislip feet

Dimensions of the product HxWxD (mm):
200x200x152 mm

KLF05CREU

KETTLES, 50'S STYLE, CREAM, FINISHING: GLOSSY



KLF05PBEU

KETTLES, 50'S STYLE, PASTEL BLUE, FINISHING: GLOSSY



KLF05PGEU

KETTLES, 50'S STYLE, PASTEL GREEN, FINISHING: GLOSSY



KLF05PKEU

KETTLES, 50'S STYLE, PINK, FINISHING: GLOSSY



KLF05RDEU

KETTLES, 50'S STYLE, RED, FINISHING: GLOSSY



KLF05WHEU

KETTLES, 50'S STYLE, WHITE, FINISHING: GLOSSY



TSF01UJEU

TOASTER 2X2, 50'S STYLE, UNION JACK, FINISHING: GLOSSY



950 W
No. of toasting levels: 6
No. of slices: 2
No. of slots: 2
Slot width: 36 mm
Automatic pop-up

Reheat function
Defrost function
Bagel function

Body material: Stainless steel
Lever material: Stainless steel
Crumb tray material: Polished steel
Buttons material: Plastic
Anti-slip feet
Integrated cord

Product dimensions: 198 x 310 (325 with ball lever included) x 195 mm

TSF01BLEU

TOASTER 2X2, 50'S STYLE, BLACK, FINISHING: GLOSSY



950 W
No. of toasting levels: 6
No. of slices: 2
No. of slots: 2
Slot width: 36 mm
Automatic pop-up

Reheat function
Defrost function
Bagel function

Body material: Stainless steel
Lever material: Stainless steel
Crumb tray material: Polished steel
Buttons material: Plastic
Anti-slip feet
Integrated cord

Product dimensions: 198 x 310 (325 with ball lever included) x 195 mm

TSF01PBEU

TOASTER 2X2, 50'S STYLE, PASTEL BLUE, FINISHING: GLOSSY



TSF01PGEU

TOASTER 2X2, 50'S STYLE, PASTEL GREEN, FINISHING: GLOSSY



TSF01CREU

TOASTER 2X2, 50'S STYLE, CREAM, FINISHING: GLOSSY



TSF01PKEU

TOASTER 2X2, 50'S STYLE, PINK, FINISHING: GLOSSY



TSF03RDEU

TOASTER 4X4, 50'S STYLE, RED, FINISHING: GLOSSY



TSF02BLEU

TOASTER 2X4, 50'S STYLE, BLACK, FINISHING: GLOSSY



1500 W
No. of toasting levels: 6
No. of slices: 4
No. of slots: 2
Slot width: 36 mm
Automatic pop-up

Reheat function
Defrost function
Bagel function

Body material: Stainless steel
Lever material: Stainless steel
Crumb tray material: Polished steel
Buttons material: Plastic
Anti-slip feet
Integrated cord

Product dimensions: 215 x 394 (410 with ball lever included) x 208 mm

TSF02CREU

TOASTER 2X4, 50'S STYLE, CREAM, FINISHING: GLOSSY



TSF02PBEU

TOASTER 2X4, 50'S STYLE, PASTEL BLUE, FINISHING: GLOSSY



TSF02PGEU

50'S STYLE, PASTEL GREEN, FINISHING: GLOSSY



TSF02PKEU

50'S STYLE, PINK, FINISHING: GLOSSY



TSF02RDEU

50'S STYLE, RED, FINISHING: GLOSSY



DCF02RDEU

DRIP FILTER COFFEE MACHINE, 50'S STYLE,
RED, FINISHING: GLOSSY



1050 W
Heating System: Heating Element
Cups capacity: 10
Water Container Capacity: 1.4 l
Display
Permanent filter material: Stainless steel /
Plastic
Caraffe capacity: 1.25 l
Decalcification alarm

Display
Buttons, Lever
1-4 cups function
Adjustable Coffee Intensity: 2 levels (Light or
Intense)
Programmable Automatic Start
Keep Warm mode
Adjustable water hardness

Stainless Steel/Plastic
Caraffe material: Glass
Antislip Base

Product Dimensions: HxLxP
361x245x256 mm

ACCESSORIES INCLUDED:
Coffee Scoop

DCF02CREU

DRIP FILTER COFFEE MACHINE, 50'S STYLE,
CREAM, FINISHING: GLOSSY



DCF02PBEU

DRIP FILTER COFFEE MACHINE, 50'S STYLE,
PASTEL BLUE, FINISHING: GLOSSY



DCF02PKEU

DRIP FILTER COFFEE MACHINE, 50'S STYLE,
PINK, FINISHING: GLOSSY



DCF02PGEU

DRIP FILTER COFFEE MACHINE, 50'S STYLE,
PASTEL GREEN, FINISHING: GLOSSY



DCF02BLEU

DRIP FILTER COFFEE MACHINE, 50'S STYLE,
BLACK, FINISHING: GLOSSY



DCF02SSEU

DRIP FILTER COFFEE MACHINE, 50'S STYLE,
STAINLESS STEEL, FINISHING: BRUSHED



MFF11BLEU

MILK FROTHER, 50'S STYLE, BLACK,
FINISHING: GLOSSY



500 W
Milk and Chocolate heating Jug capacity:
600 ml / 2.5 cup
Milk frothing Jug capacity: 250 ml / 1 cup
Removable Carafe
Removable measuring cup/lid
Button , Knob
Induction system with automatic switch off

Cold Froth Dense function
Cold Froth Light function
Hot Froth Dense function
Hot Froth Light function
Hot Milk function
Hot Chocolate function
Manual Cold function
Manual Hot function

Body material: Stainless steel
Carafe material: Stainless steel
Lid material: Tritan™ Renew
Antislip Base: Yes
Integrated cord wrap

Product Dimensions W x H x D: HxLxP 251 x
184 x 142 mm

ACCESSORIES INCLUDED:

Smooth Disc for Hot Milk and Manual
functions
Notched Disc for Froth and Manual functions

MFF11CREU

MILK FROTHER, 50'S STYLE, CREAM,
FINISHING: GLOSSY



MFF11PGEU

MILK FROTHER, 50'S STYLE, PASTEL GREEN,
FINISHING: GLOSSY



MFF11PBEU

MILK FROTHER, 50'S STYLE, PASTEL BLUE,
FINISHING: GLOSSY



MFF11PKEU

MILK FROTHER, 50'S STYLE, PINK,
FINISHING: GLOSSY



MFF11WHEU

MILK FROTHER, 50'S STYLE, WHITE,
FINISHING: GLOSSY



CGF11BLEU

COFFEE GRINDER, 50'S STYLE, BLACK,
FINISHING: GLOSSY



150 W
RPM: 450
Burr type: conical
Antistatic system
Coffee bean container capacity: 350 gr
Ground coffee container capacity: 130 g
Ground coffee container with Twist & Lock system

Adjustable grinding size
Available grinding steps: FINE , MEDIUM ,
COARSE
Manual function

Body material: Stainless Steel
Coffee bean container material: BPA-free plastic
Ground coffee container material: BPA-free plastic
Container support plate material: Steel
Antislip base
Built-in cord wrap

Product Dimensions W x H x D: 220 x
385 x 150 mm

ACCESSORIES INCLUDED:

Centering filter support
Powder container support
Cleaning brush

CGF11CREU

COFFEE GRINDER, 50'S STYLE, CREAM,
FINISHING: GLOSSY



CGF11PBEU

COFFEE GRINDER, 50'S STYLE, PASTEL
BLUE, FINISHING: GLOSSY



CGF11PGEU

COFFEE GRINDER, 50'S STYLE, PASTEL
GREEN, FINISHING: GLOSSY



CGF11RDEU

COFFEE GRINDER, 50'S STYLE, RED,
FINISHING: GLOSSY



CGF11WHEU

COFFEE GRINDER, 50'S STYLE, WHITE,
FINISHING: GLOSSY



ECF02BLEU

ESPRESSO COFFEE MACHINE, 50'S STYLE,
BLACK, FINISHING: GLOSSY



1350 W
Heating System: Thermoblock
Pump Pressure: 15 bar
Water Container Capacity: 1 l
Removable Water Container
Passive
Removable Drip Tray
Paper Pods Filter
Decalcification alarm
Buttons, Lever
Hot Water Function
Adjustable Stand-by Function
Adjustable Coffee Temperature: low/
medium/high
Adjustable coffee length
Adjustable water hardness
Stand-by setting: 9 min/30 min/3 hrs

Stainless Steel/Plastic
Cup Warmer Material: Stainless steel
Drip Tray Material: Plastic
Antislip Base

Product Dimensions: HxLxP
330x149x329 mm

ACCESSORIES INCLUDED:

Double Wall 1 Cup Filter
Double wall 2 Cups Filter
Paper Pods Filter
Measurer/Tamper

ECF02RDEU

ESPRESSO COFFEE MACHINE, 50'S STYLE,
RED, FINISHING: GLOSSY



ECF02PBEU

ESPRESSO COFFEE MACHINE, 50'S STYLE,
PASTEL BLUE, FINISHING: GLOSSY



ECF02WHEU

ESPRESSO COFFEE MACHINE, 50'S STYLE,
WHITE, FINISHING: GLOSSY



ECF02PGEU

ESPRESSO COFFEE MACHINE, 50'S STYLE,
PASTEL GREEN, FINISHING: GLOSSY



ECF02CREU

ESPRESSO COFFEE MACHINE, 50'S STYLE,
CREAM, FINISHING: GLOSSY



ECF03BLEU

ESPRESSO COFFEE MACHINE, 50'S STYLE,
BLACK, FINISHING: GLOSSY



1600 W
Espresso coffee Machine
Cold Brew Function
Heating System: Thermoblock
Pump Pressure: 19 bar
Water Container Capacity: 1.4 l
Removable Water Container
Passive Warmer
Removable Drip Tray
Decalcification alarm
Buttons, Lever
Hot Water Function
Adjustable Stand-by Function
Adjustable Coffee Temperature: low/
medium/high
Adjustable coffee length
Adjustable water hardness
Stand-by setting: 10 min/30 min/60 min

Stainless Steel/Die-cast aluminum
Cup Warmer Material: Stainless steel
Drip Tray Material: Plastic
Antislip Base

Product Dimensions: HxWxD
465x416x304 mm

ACCESSORIES INCLUDED:

Double Wall 1 Cup Filter
Double wall 2 Cups Filter
Single Wall 1 Cup Filter
Single wall 2 Cups Filter
Tamper

ECF03RDEU

ESPRESSO COFFEE MACHINE, 50'S STYLE,
RED, FINISHING: GLOSSY



ECF03PBEU

ESPRESSO COFFEE MACHINE, 50'S STYLE,
PASTEL BLUE, FINISHING: GLOSSY



ECF03WHEU

ESPRESSO COFFEE MACHINE, 50'S STYLE,
WHITE, FINISHING: GLOSSY



ECF03PGEU

ESPRESSO COFFEE MACHINE, 50'S STYLE,
PASTEL GREEN, FINISHING: GLOSSY



ECF03CREU

ESPRESSO COFFEE MACHINE, 50'S STYLE,
CREAM, FINISHING: GLOSSY



EGF03BLEU

ESPRESSO COFFEE MACHINE, 50'S STYLE,
BLACK, FINISHING: GLOSSY



1650 W

Espresso coffee Machine with Grinder

Heating System: Double Thermoblock

Pump Pressure: 15 bar

Water Container Capacity: 2.4 l

Removable Water Container

Passive

Removable Drip Tray

Paper Pods Filter

Decalcification alarm

Buttons, Lever

Hot Water Function

Adjustable Stand-by Function

Adjustable Coffee Temperature: low/
medium/high

Adjustable coffee length

Adjustable water hardness

Stand-by setting: 10 min/30 min/
40 min/60 min

Stainless Steel/Plastic

Cup Warmer Material: Stainless steel

Drip Tray Material: Plastic

Antislip Base

Product Dimensions: HxWxD

443x334x430 mm

ACCESSORIES INCLUDED:

Double Wall 1 Cup Filter

Double wall 2 Cups Filter

Paper Pods Filter

Measurer/Tamper

EGF03RDEU

ESPRESSO COFFEE MACHINE, 50'S STYLE,
RED, FINISHING: GLOSSY



EGF03WHEU

ESPRESSO COFFEE MACHINE, 50'S STYLE,
WHITE, FINISHING: GLOSSY



EGF03PBEU

ESPRESSO COFFEE MACHINE, 50'S STYLE,
PASTEL BLUE, FINISHING: GLOSSY



EGF03PGEU

ESPRESSO COFFEE MACHINE, 50'S STYLE,
PASTEL GREEN, FINISHING: GLOSSY



EGF03CREU

ESPRESSO COFFEE MACHINE, 50'S STYLE,
CREAM, FINISHING: GLOSSY



BCC13BLMEU

ESPRESSO COFFEE MACHINE, 50'S STYLE,
BLACK, FINISHING: MATT



1350 W
Heating System: Thermoblock
Pump Pressure: 19 bar
Coffee grain container capacity: 150 g
Water Container Capacity: 1.4 l
Adjustable height dispenser
Removable Drip Tray
Min/Max coffee dispenser level:
90/135 mm (185 mm without drip tray)
Decalcification alarm
Buttons
White Menu: Espresso
Orange Menu: Espresso Light
Adjustable grinding level
Adjustable coffee length
Adjustable water hardness

Plastic
Cup Tray Finishing: Brushed with polished
edge
Jug material: Stainless steel
Front panel material: Aluminium
Steam nozzle material: Stainless steel

Product Dimensions: HxLxP
336x180x433 mm

ACCESSORIES INCLUDED:

Cleaning brush
Water hardness test strip
Milk bottle with lid
Milk pipe
Milk pipe cleaning needle

BCC13EGMEU

ESPRESSO COFFEE MACHINE, 50'S STYLE,
EMERALD GREEN, FINISHING: MATT



BCC13WHMEU

ESPRESSO COFFEE MACHINE, 50'S STYLE,
WHITE, FINISHING: MATT



BCC13SBMEU

ESPRESSO COFFEE MACHINE, 50'S STYLE,
STROM BLUE, FINISHING: MATT



BCC12BLMEU

ESPRESSO COFFEE MACHINE, 50'S STYLE,
BLACK, FINISHING: MATT



1350 W
Heating System: Thermoblock
Pump Pressure: 19 bar
Coffee grain container capacity: 150 g
Water Container Capacity: 1.4 l
Adjustable height dispenser
Removable Drip Tray
Min/Max coffee dispenser level:
90/135 mm (185 mm without drip tray)
Decalcification alarm
Buttons
Primary Menu function
White Menu: Ristretto
Secondary Menu Function
Orange Menu: Ristretto Light
Adjustable grinding level
Adjustable coffee length
Adjustable water hardness

Plastic
Cup Tray Finishing: Brushed with polished
edge
Jug material: Stainless steel
Front panel material: Aluminium
Steam nozzle material: Stainless steel

Product Dimensions: HxLxP
336x180x433 mm

ACCESSORIES INCLUDED:

Cleaning brush
Water hardness test strip
Steam wand cleaning needle

BCC12EGMEU

ESPRESSO COFFEE MACHINE, 50'S STYLE,
EMERALD GREEN, FINISHING: MATT



BCC12SBMEU

ESPRESSO COFFEE MACHINE, 50'S STYLE,
STROM BLUE, FINISHING: MATT



ACCESSORIES FOR SMALL DOMESTIC APPLIANCES

SMMG01

MULTI FOOD GRINDER



Alluminum alloy body, ferrule and cochlea. Included accessories: 3 stainless steel discs for mincing (coarse Ø 8 mm, medium Ø 4,2 mm, fine Ø 3 mm), plastic Sausages and Kebbe accessory, a silicon disc for cleaning and a pestel to introduce better the ingredients.

SMPC01

PASTA ROLLER AND CUTTER SET (3 ACCESSORIES)



Pasta roller, tagliolini cutter and fettuccine cutter. Chrome steel body. Chrome steel.

SMPR01

PASTA ROLLER



Chrome steel body
Anodized aluminium alloy rolls
10 setting to adjust dough thickness (from 4,8 mm at n.0 setting to 0,6 mm at n. 9 setting).
Max dough width: 140 mm
Not dishwasher safe
Small brush for cleaning included

SMSG01

SLICER & GRATER (4 ACCESSORIES)



Grater accessory body and plastic pestle. Security handle to facilitate removal/insertion of the cylinder in the body. Stainless steel lock/unlock system to help changing cylinders. Included accessories are 4 drums for slicing and grating: 1. medium slicer 2. fine slicer 3. coarse grater 4. medium grater. Not dishwasher safe.

SMFB02

FLEX EDGES BEATER



Stainless steel beater with flexible silicone edges. Useful for mixing doughs and soft batters.

SMDH01

DOUGH HOOK



Aluminum dough hook to combine and mix leavened doughs, such as those for pasta and pizza, in the best possible way.

SMFB01

FLAT BEATER



Aluminum flat beater to combine dense mixtures such as those for cakes, frosting, biscuits, and purées.

SMWW02

WIRE WHISK



Alluminum body whisk and Stainless steel wire whisk to whip up egg whites, yolks, cream, and make custards and sauces. Not dishwasher safe.

ACCESSORIES FOR STAND MIXER

SMIC01

ICE CREAM MAKER ACCESSORY



Ice Cream maker accessory for the production of ice cream, sorbet and frozen yoghurt. Cold accumulating double wall cooling container. Production up to 1,1 Lt (1.2 Qt / 37 oz) in about 20/30 minutes. Ice cream maker accessory ONLY suitable for SMEG stand mixers with St/ steel bowl SMB401.

SMIC02

ADDITIONAL CONTAINER FOR ICE CREAM MAKER ACCESSORY SMIC01



Ice cream maker accessory for the production of ice cream, sorbet and frozen yoghurt. Cold accumulating double wall cooling container. 1.1 Lt (1.2 Qt / 37 oz) internal container contains ingredients up to 700 gr / 1 lb. Ice Cream Maker accessories fit ONLY on SMEG stand mixer with St/steel bowl SMB401.

SMB401

STAINLESS STEEL BOWL 4,8 L



4.8L polished stainless steel bowl with ergonomic handle. Dishwasher safe.

SMGB01

GLASS BOWL 4,8 L



4.8 L glass bowl with ergonomic handle. Dishwasher safe.

SMP501

POURING SHIELD



The pouring shield prevents splashes coming out and, at the same time, its spout simplifies the addition of ingredients during mixing. Plastic Body not dishwasher safe.

ACCESSORIES FOR BLENDER

BGF01

BOTTLE TO GO, FAMILY GROUP: BLENDER



600 ml/20 OZ bottle to be used with the blender BLF01. The accessory allows to prepare your personal smoothie on the go. Included in the package: bottle, lid and spout in TritanRenew, stainless steel blade unit. Dishwasher safe: bottle, lid, spout.

BGF02

WATER BOTTLE FOR CITRUS JUICER, MILK FROTHER, SLOW JUICERS, BLENDER



600 ml/ 20 OZ bottle BPA free with silicon seal for leak-proof use on the go. The BGF02 accessory allows consumers to always have their handy favourite smoothy or beverage for consumption during all their daily activities out of home.

ACCESSORIES FOR TOASTER

TSSR01

2-PIECE SANDWICH RACKS



Steel grill and steel bottom box
Plastic handles with anti-heat treatment

TSSR02

2-PIECE SANDWICH RACKS



Sandwich rack set (2 pcs)
Steel grill and steel bottom box
Plastic handles with anti-heat treatment

TSBW01

BUN WARMER

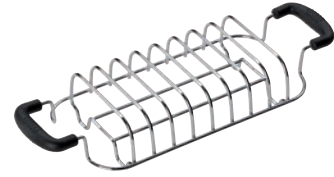

Steel grill
Plastic handles with anti-heat treatment

TSBW02

BUN WARMER

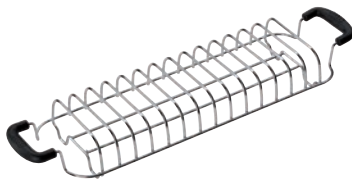

Steel grill
Plastic handles with anti-heat treatment

ACCESSORY FOR DRIP COFFEE MACHINE

DCGC01

CARAFE



Glass carafe with lid. 10 cups capacity.
Suitable for drip coffee machines.

ACCESSORIES FOR COFFEE MACHINES

ECTS01

COFFEE TAMPER



Calibrated stainless steel coffee tamper
ø51 mm with ergonomic aluminum handle. Ideal to press coffee at the right point, compatible with ECF01 filter holder. The molded silicone mat, is the perfect support base to facilitate the coffee pressing phases, protecting the work surface and the filter holder at the same time.

1ECWF01

WATER FILTER



Compatible with Manual Espresso Coffee Machine ECF01 and Full Automatic Espresso Machine BCC01/02

ECWF01

WATER FILTER

10 pieces box.
Compatible with Manual Espresso Coffee Machine ECF01 and Full Automatic Espresso Machine BCC01/02

Quality, Environmental and Occupational Health & Safety Management Systems

All Smeg factories are ISO9001, ISO14001 and OHSAS 18001 certified, ensuring that the highest standards of quality are continually maintained whilst actively responding to all environmental issues relating to manufacture. The materials and components used to produce smeg products undergo strict quality control testing, and care is taken to source recyclable materials wherever possible. These management systems enable Smeg to provide complete assurance that all products meet superior standards whilst respecting the environment. The workforce is not forgotten – the occupational health and safety assessment scheme promotes a safe and healthy working environment, aids legislative compliance and helps improve overall performance.



UNI EN ISO 9001



UNI EN ISO 14001



OHSAS 18001

Whereas every effort has been made to ensure that the information contained in our literature is correct at time of going to print, this brochure should not be regarded as an infallible guide to current specification, nor does it constitute an offer for sale of any particular product. Smeg reserves the right to change specification without notice.



Energia Appliances Pvt. Ltd.

201, 2nd Floor, Metro Avenue, Near WEH Metro Stn., Mota Nagar, Andheri East, Mumbai - 400099

Service Dept

Tel: 022 46722400 | Toll Free No: 18001036128

www.energia.ind.in | www.smeg.com/in

Sales ID : sales@energia.ind.in , info@smeg.in

Brand Stores

Gr. Floor, Paragon Center, Pandhurang Budhakar Marg, Worli, Mumbai - 400013

Gr. Floor, Hara Chambers, No.22, K H Road, Srinivas Colony, Bengaluru - 560027

Gr. Floor, khasra No.349, Sulatanpur, MG Road, New Delhi - 110030

Sales Locations

West – Mumbai | Pune | Nagpur | Nasik | Goa | Gujarat | Indore | Raipur

North: Delhi | NCR | Chandigarh | Ludhiana | Jaipur | Udaipur

South: Bangalore | Hyderabad | Chennai | Kochi | Coimbatore